



Technical Data Sheet

Right Angle Lens Chip LEDs with Bi-Color(Multi-Color)

12-22ASDRSYGC/S530-A5/E3/TR8

Features

- Package in 8mm tape on 7" diameter reel.
- Compatible with automatic placement equipment.
- Compatible with infrared and vapor phase reflow solder process.
- Multicolor type.

Descriptions

- The 12-22A SMD Taping is much smaller than lead frame type components, thus enable smaller board size, higher packing density, reduced storage space and finally smaller equipment to be obtained.
- Besides, lightweight makes them ideal for miniature applications. etc.

Applications

- Automotive: backlighting in dashboard and switch.
- Telecommunication: indicator and backlighting in telephone and fax.
- Flat backlight for LCD, switch and symbol.
- General use.



Device Selection Guide

Chip			Lens Color
Type	Material	Emitted Color	
SDR	AlGaInP	Super Deep Red	Water Clear
SYG	AlGaInP	Super Yellow Green	

12-22ASDRSYGC/S530-A5/E3/TR8

Package Outline Dimensions

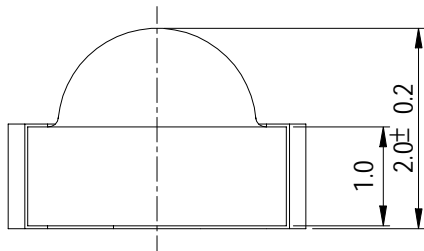
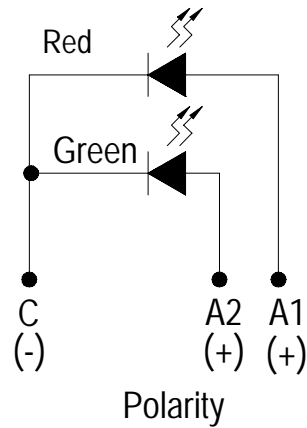
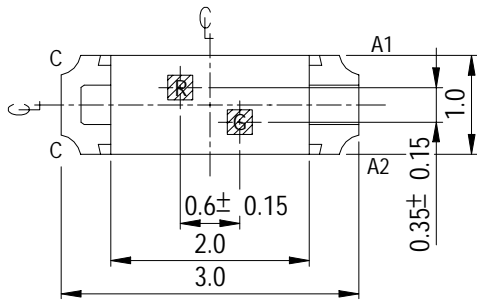

For reflow soldering (propose)

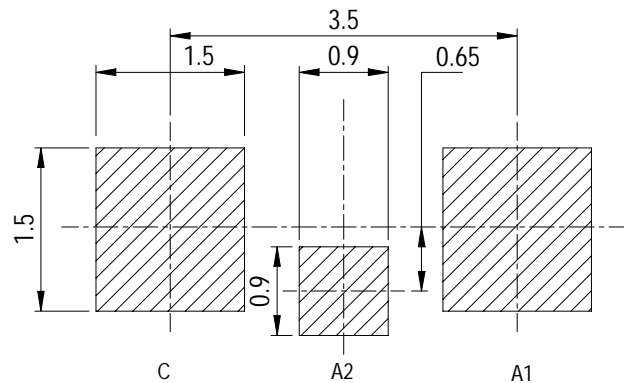
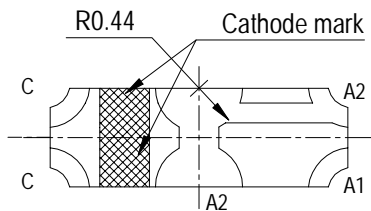

Note: Tolerances Unless Dimension $\pm 0.1\text{mm}$, Angle $\pm 0.5^\circ$,Unit = mm

12-22ASDRSYGC/S530-A5/E3/TR8
Absolute Maximum Ratings (Ta=25°C)

Parameter	Symbol	Rating	Unit
Reverse Voltage	V _R	5	V
Forward Current	I _F	SDR:25 SYG:25	mA
Operating Temperature	Topr	-40 ~ +85	°C
Storage Temperature	Tstg	-40~ +90	°C
Soldering Temperature	Tsol	260 (for 5 second)	°C
Electrostatic Discharge	ESD	2000	V
Power Dissipation	Pd	SDR:60 SYG:60	mW
Peak Forward Current (Duty 1/10 @1KHz)	I _F	SDR:60 SYG:60	mA

Electro-Optical Characteristics (Ta=25°C)

Parameter	Symbol	Min.	Typ.	Max.	Unit	Condition
Luminous Intensity	I _v SDR	43	68	-----	mcd	I _F =20mA
	SYG	32	41	-----		
Viewing Angle	2θ 1/2	-----	120	-----	deg	I _F =20mA
Peak Wavelength	λ _p SDR	-----	650	-----	nm	I _F =20mA
	SYG	-----	575	-----		
Dominant Wavelength	λ _d SDR	-----	639	-----	nm	I _F =20mA
	SYG	-----	573	-----		
Spectrum Radiation Bandwidth	Δλ SDR	-----	20	-----	nm	I _F =20mA
	SYG	-----	20	-----		
Forward Voltage	V _F SDR	-----	2.0	2.4	V	I _F =20mA
	SYG	-----	2.0	2.4		
Reverse Current	I _R SDR	-----	-----	10	μA	V _R =5V
	SYG	-----	-----	10		

12-22ASDRSYGC/S530-A5/E3/TR8

**Typical Electro-Optical Characteristics Curves
SDR**

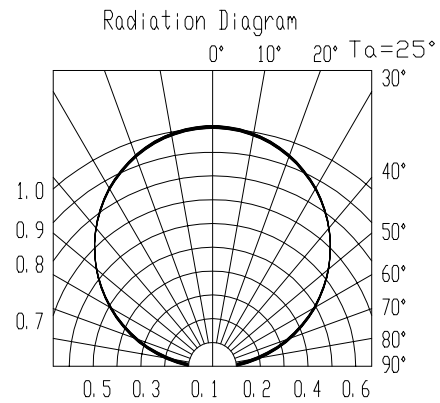
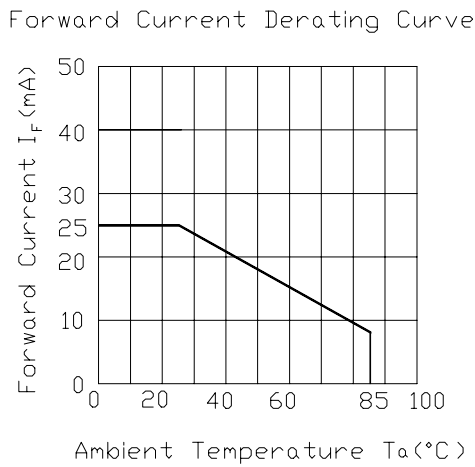
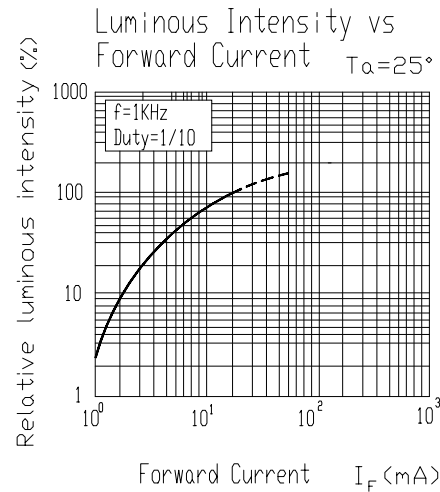
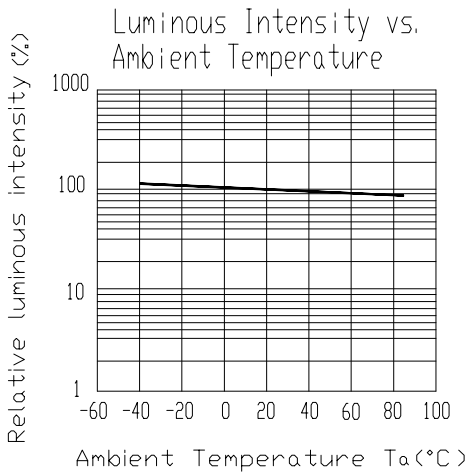
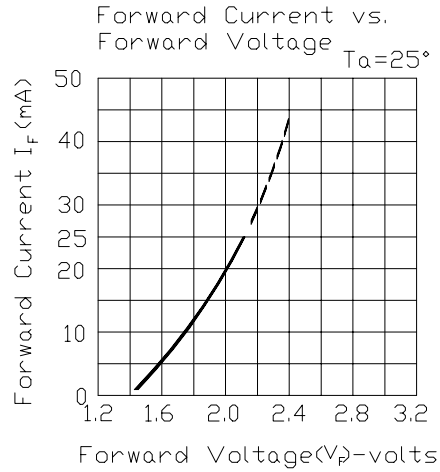
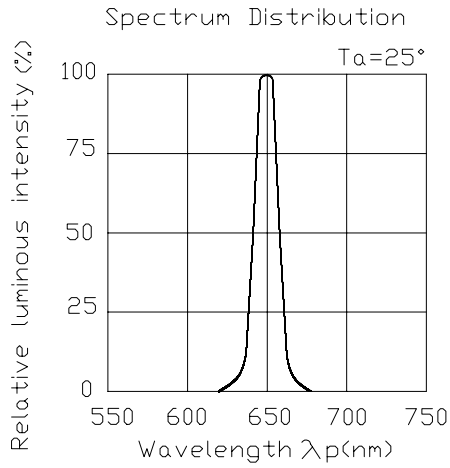

12-22ASDRSYGC/S530-A5/E3/TR8

**Typical Electro-Optical Characteristics Curves
SYG**

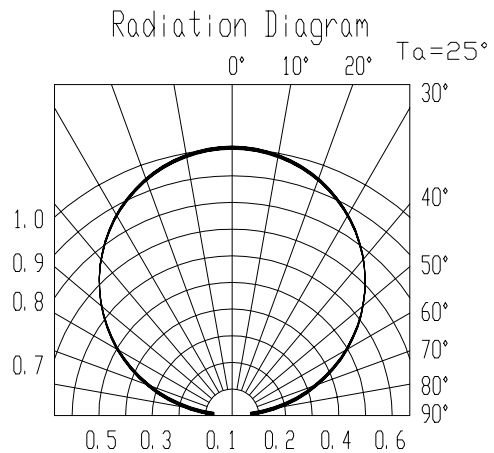
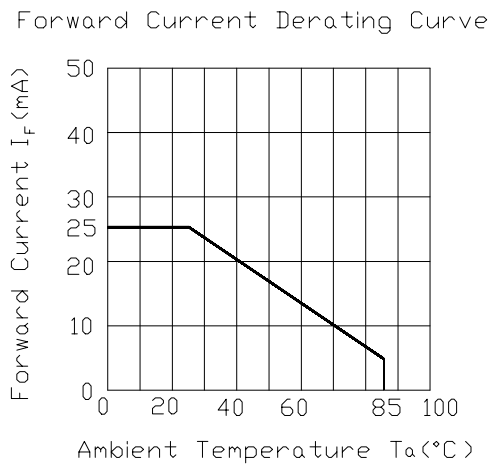
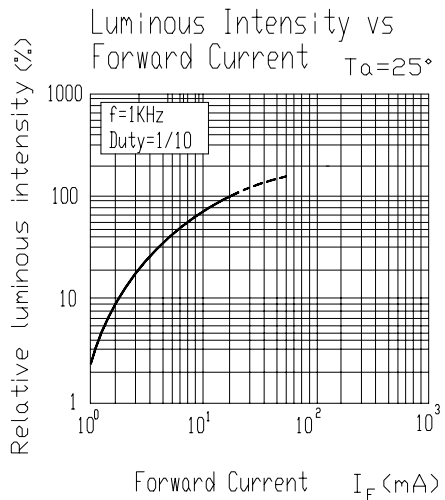
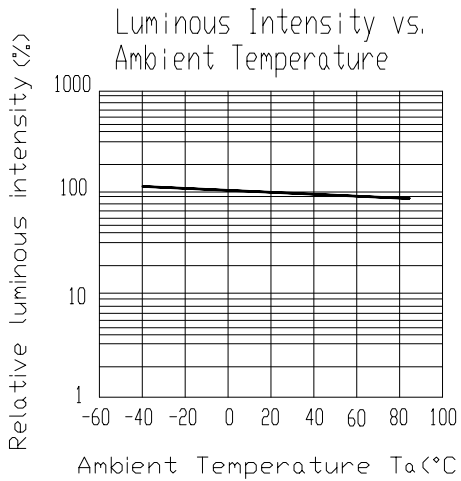
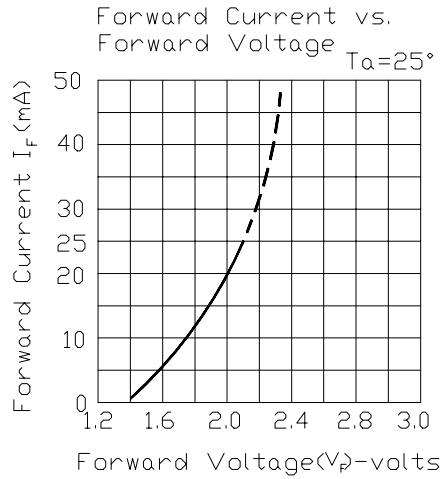
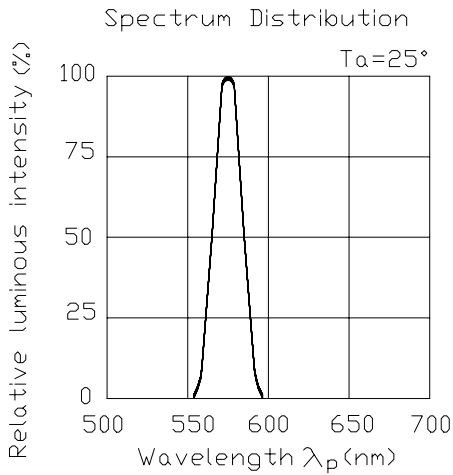

12-22ASDRSYGC/S530-A5/E3/TR8

■ **Label explanation**

CAT: Luminous Intensity (mcd)

HUE: Dom. Wavelength (nm)

REF: Forward Voltage (V)

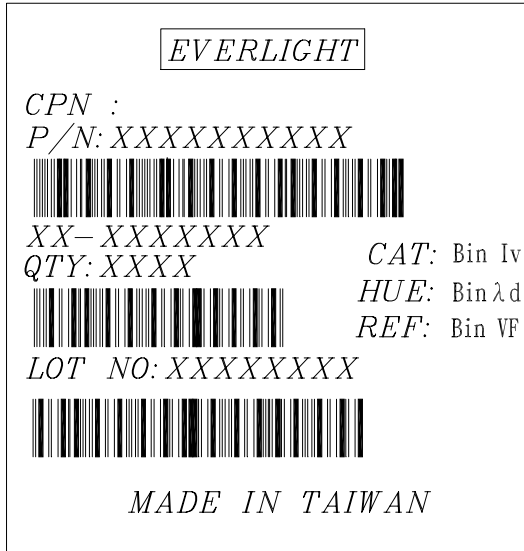

■ **Reel Dimensions**

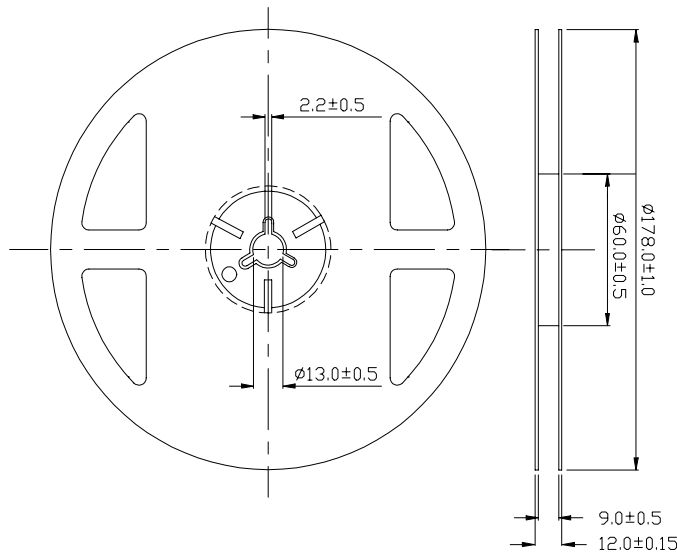

Note: Tolerances Unless Dimension $\pm 0.1\text{mm}$, Angle $\pm 0.5^\circ$,Unit = mm

12-22ASDRSYGC/S530-A5/E3/TR8

Carrier Tape Dimensions: Loaded quantity 2000 PCS per reel

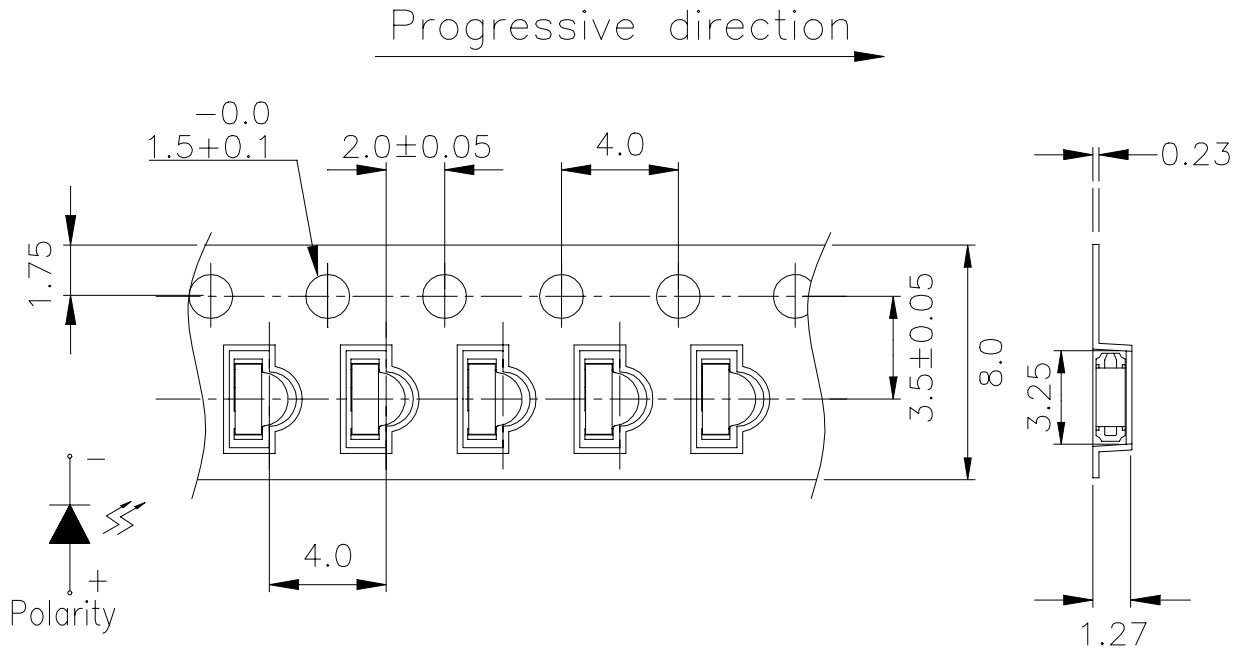

Note: Tolerances Unless Dimension $\pm 0.1\text{mm}$, Angle $\pm 0.5^\circ$,Unit = mm

Moisture Resistant Packaging

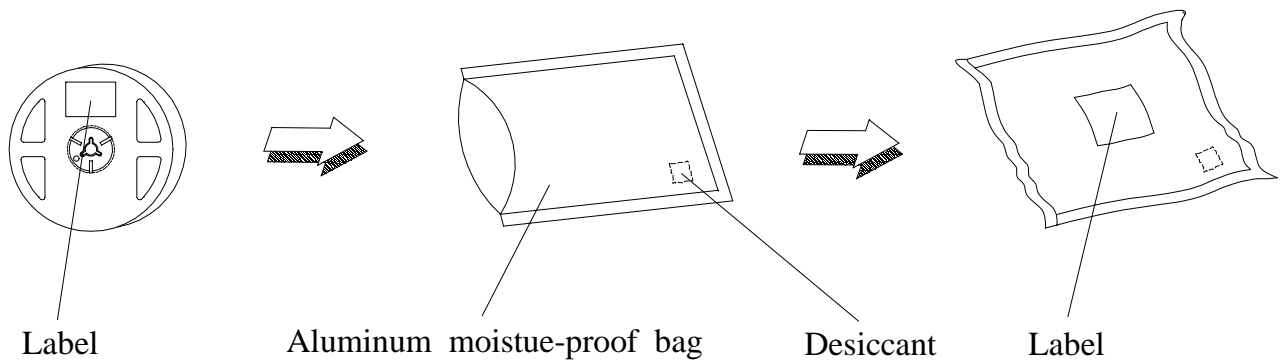

12-22ASDRSYGC/S530-A5/E3/TR8**Reliability Test Items And Conditions**

The reliability of products shall be satisfied with items listed below.

Confidence level : 90 %

LTPD : 10 %

No.	Items	Test Condition	Test Hours/Cycles	Sample Size	Ac/Re
1	Reflow	Temp. : 240°C ± 5°C Min. 5 sec.	6 min.	22 Pcs.	0/1
2	Temperature Cycle	H : +100°C 15min. ∫ 5 min. L : -40°C 15min.	300 Cycles	22 Pcs.	0/1
3	Thermal Shock	H : +100°C 5min. ∫ 10 sec. L : -10°C 5min.	300 Cycles	22 Pcs.	0/1
4	High Temperature Storage	Temp. : 100°C	1000 Hrs.	22 Pcs.	0/1
5	Low Temperature Storage	Temp. : -55°C	1000 Hrs.	22 Pcs.	0/1
6	DC Operating Life	I _F = 20 mA	1000 Hrs.	22 Pcs.	0/1
7	High Temperature / High Humidity	85°C/R.H85%	1000 Hrs.	22 Pcs.	0/1

12-22ASDRSYGC/S530-A5/E3/TR8

Precautions For Use

1. Over-current-proof

Customer must apply resistors for protection , otherwise slight voltage shift will cause big current change (Burn out will happen).

2. Storage time

2.1 The operation of Temperature and RH are : 5°C~35°C , RH60%.

2.2 Once the package is opened, the products should be used within a week.

Otherwise, they should be kept in a damp proof box with desiccating agent.

Considering the tape life , we suggest our customers to use our products within a year(from production date).

2.3 If opened more than one week in an atmosphere 5°C~35°C , RH 60% , they should be treated at 60°C± 5°C for 15hrs.

2.4 When you discover that the desiccant in the package has a pink color (Normal = blue) , you should treat them in the same conditions as 2.3.

Soldering heat

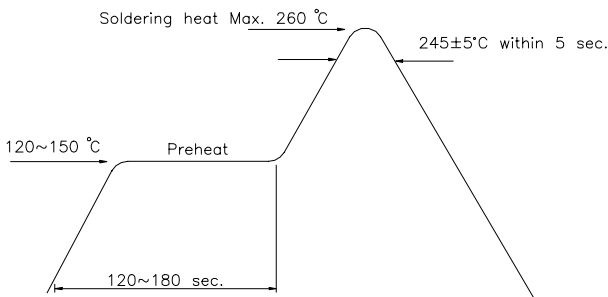

Reflow Temp / Time

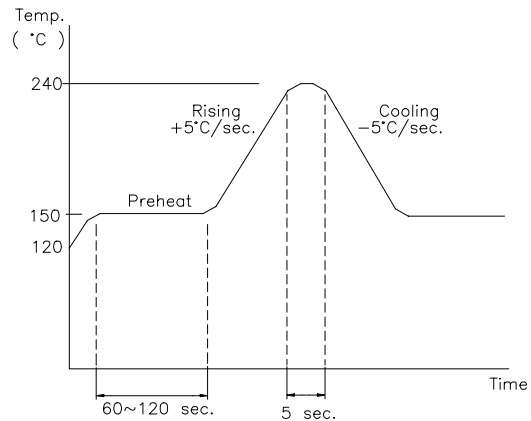

Soldering Iron

Basic spec is ≤ 5 sec when 260°C. If temperature is higher, time should be shorter (+10°C → -1sec). Power dissipation of Iron should be smaller than 15 W , and temperature should be controllable. SDRface temperature of the device should be under 230 °C .

Rework

1. Customer must finish rework within 5 sec under 245°C.
2. The head of iron can not touch copper foil.
3. Twin-head type is preferred.

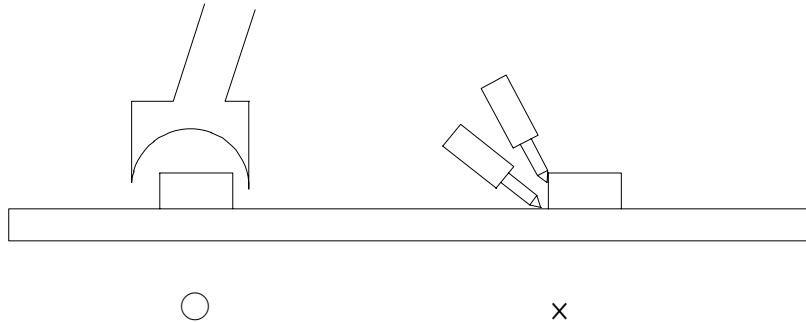

EVERLIGHT ELECTRONICS CO., LTD.
Office: No 25, Lane 76, Sec 3, Chung Yang Rd,
Tucheng, Taipei 236, Taiwan, R.O.C

Tel: 886-2-2267-2000, 2267-9936
Fax: 886-2267-6244, 2267-6189, 2267-6306
<http://www.everlight.com>