



MODEL NO: 24-21UYC/S530-A2/TR8

Device Number : DSE-241-017 REV. 1.0

**Reverse Package Chip LED**

ECN : \_\_\_\_\_ Page: 1/8

■ **Features :**

- Package in 8mm tape on 7" diameter reel.
- Compatible with automatic placement equipment.
- Compatible with infrared and vapor phase reflow solder process.
- Mono-color type.

■ **Description :**

- The 24-21 SMD Taping is much smaller than leaded components, thus enable smaller board size, higher packing density, reduced storage space and finally smaller equipment to be obtained.
- Besides, lightweight makes them ideal for miniature application, etc.

■ **Applications :**

- Automotive: backlighting in dashboard and switch.
- Telecommunication: indicator and backlighting in telephone and fax.
- Flat backlight for LCD, switch and symbol.
- General use.

■ **Package Dimensions :**

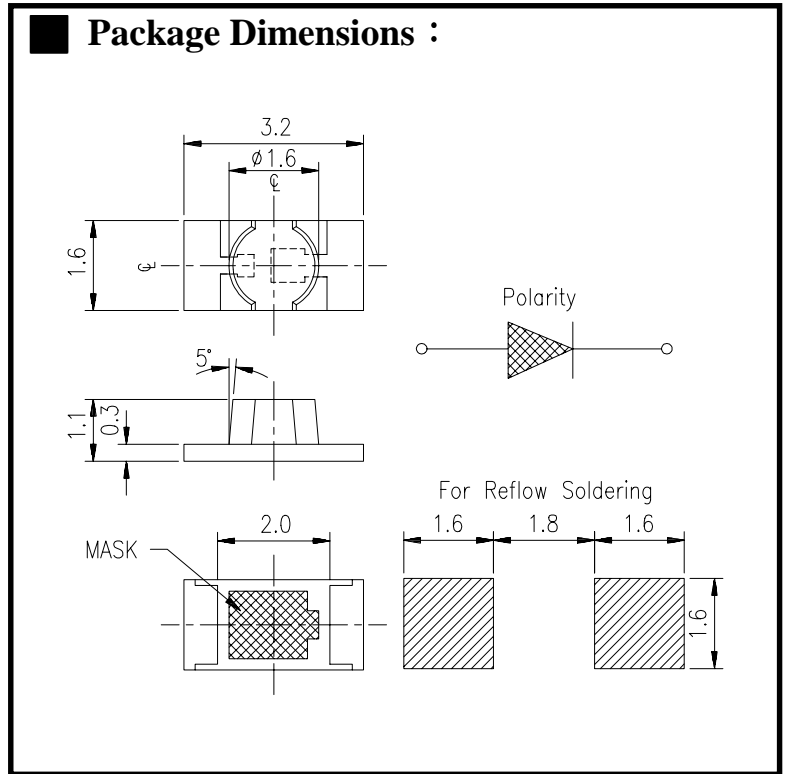

■ **Notes :**

Tolerances Unless Dimension  $\pm$  0.1mm  
Angle  $\pm 0.5^\circ$

PART NO	CHIP		Lens Color
	Material	Emitted Color	
24-21UYC/S530-A2/TR8	AlGaInP	Super Yellow	Water Clear

Office: NO 25,Lane.76, Chung Yang Rd., Sec.3, Tucheng, Taipei 236, Taiwan, R.O.C.

TEL: 886-2-2267-2000,2266-9936(22 Lines)

FAX: 886-2-2267-6189

<http://www.everlight.com>



MODEL NO: 24-21UYC/S530-A2/TR8

Device Number : DSE-241-017 REV. 1.0

*Reverse Package Chip LED*

ECN : \_\_\_\_\_ Page: 2/8

■ Package Dimensions :

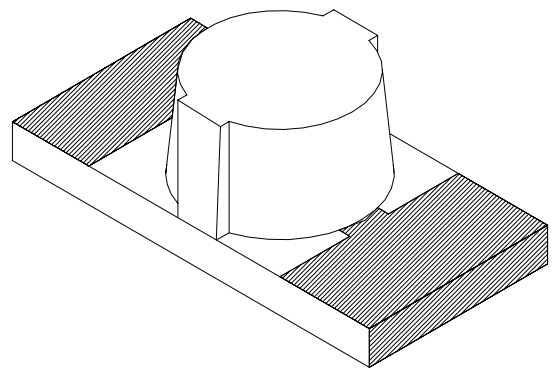
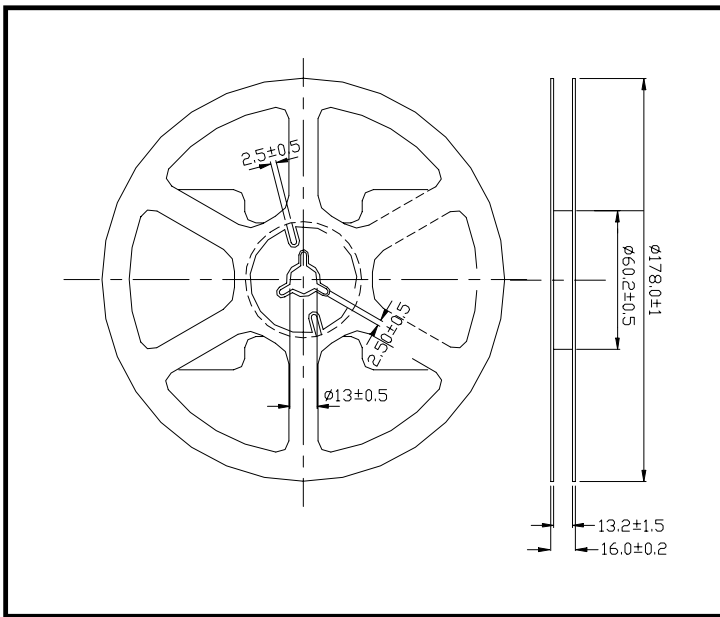

■ Loaded quantity per reel 2000 pcs/reel :

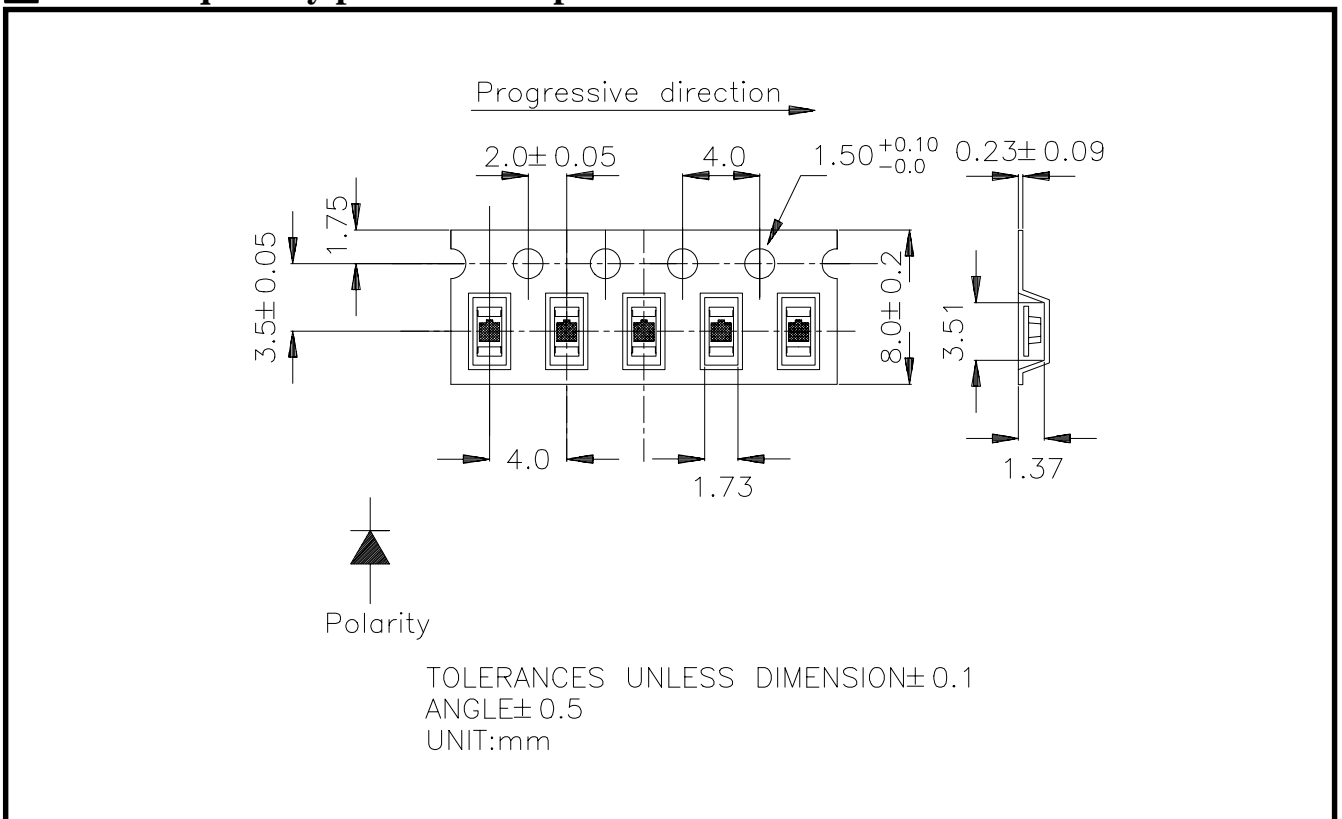



MODEL NO: 24-21UYC/S530-A2/TR8

Device Number : DSE-241-017 REV. 1.0

**Reverse Package Chip LED**

ECN : \_\_\_\_\_ Page: 3/8

■ **Absolute Maximum Ratings at Ta = 25°C :**

Parameter	Symbol	Rating	Unit
Reverse Voltage	Vr	5	V
Forward Current	If	25	mA
Operating Temperature	Topr	-40 ~ +85	°C
Storage Temperature	Tstg	-40 ~ +90	°C
Soldering Temperature	Tsol	260 (for 5 second)	°C
Electrostatic Discharge	ESD	2000	V
Power Dissipation	Pd	60	mW
Peak Forward Current(Duty 1/10 @ 1KHZ)	If(Peak)	160	mA

■ **Electronic Optical Characteristics :**

Parameter	Symbol	Min.	Typ.	Max.	Unit	Condition
Luminous intensity	Iv	-----	2	-----	mcd	If=2mA
Luminous intensity	Iv	16	41	-----	mcd	If=20mA
Viewing Angle	2θ 1/2	-----	130	-----	deg	If=20mA
Peak Wavelength	λp	-----	591	-----	nm	If=20mA
Dominant Wavelength	λd	-----	589	-----	nm	If=20mA
Spectrum Radiation Bandwidth	Δλ	-----	15	-----	nm	If=20mA
Forward Voltage	Vf	-----	2.0	2.4	V	If=20mA
Reverse Current	Ir	-----	-----	10	μA	Vr=5V



MODEL NO: 24-21UYC/S530-A2/TR8

Device Number : DSE-241-017 REV. 1.0

*Reverse Package Chip LED*

ECN : \_\_\_\_\_ Page: 4/8

■ Reliability Test Item And Condition :

NO	Item	Test Conditions	Test Hours/Cycle	Sample Size	Ac/Re
1	Solder Heat	TEMP : 260°C ± 5 °C	5 SEC	76 Pcs	0/1
2	Temperature Cycle	H : +85°C 30min § 5 min L : -55°C 30min	50 CYCLE	76 Pcs	0/1
3	Thermal Shock	H : +100°C 5min § 10 sec L : -10°C 5min	50 CYCLE	76 Pcs	0/1
4	High Temperature Storage	TEMP : 100°C	1000 HRS	76 Pcs	0/1
5	Low Temperature Storage	TEMP : -55°C	1000 HRS	76 Pcs	0/1
6	DC Operating Life	If = 20 mA	1000 HRS	76 Pcs	0/1
7	High Temperature / High Humidity	85°C/85% RH	1000 HRS	76 Pcs	0/1



MODEL NO: 24-21UYC/S530-A2/TR8

Device Number : DSE-241-017 REV. 1.0

**Reverse Package Chip LED**

ECN : ..... Page: 5/8

■ **Typical Electro-Optical Characteristic Curves :**

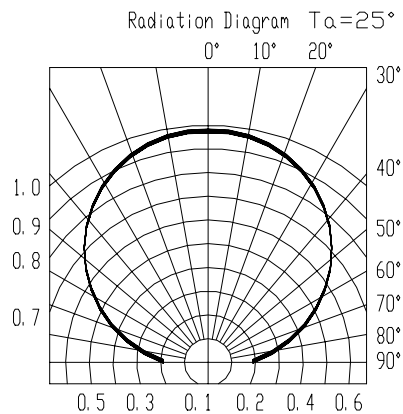
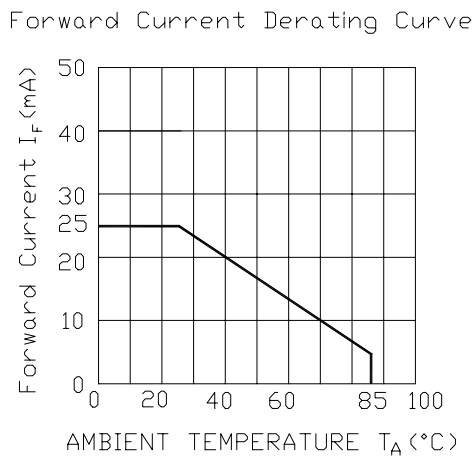
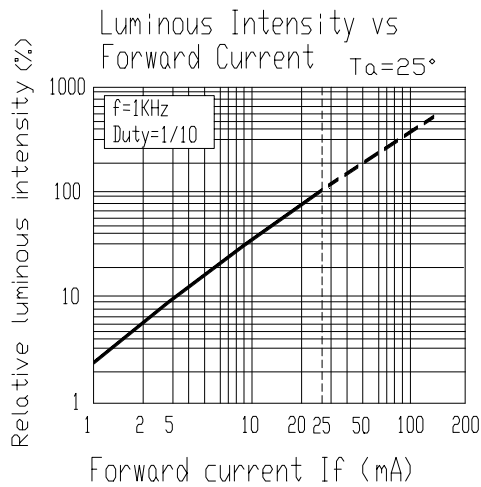
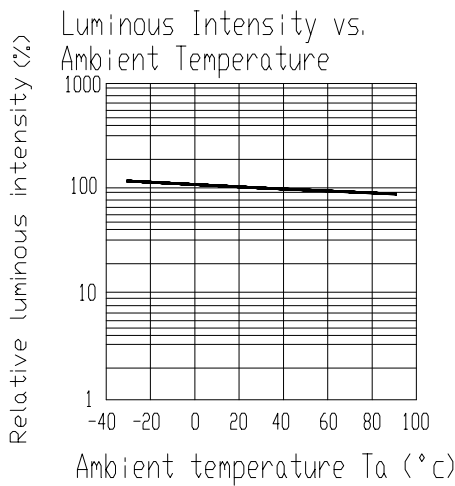
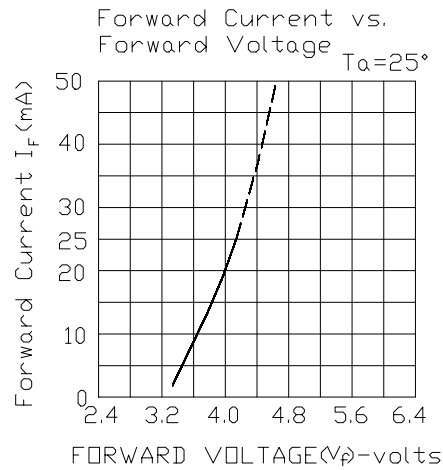
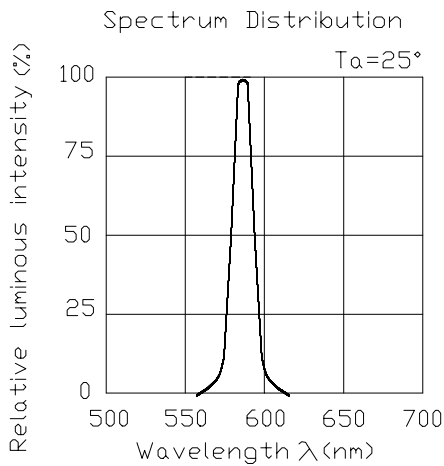



MODEL NO: 24-21UYC/S530-A2/TR8

Device Number : DSE-241-017 REV. 1.0

**Reverse Package Chip LED**

ECN : ..... Page: 6/8

■ **Test Circuit :**

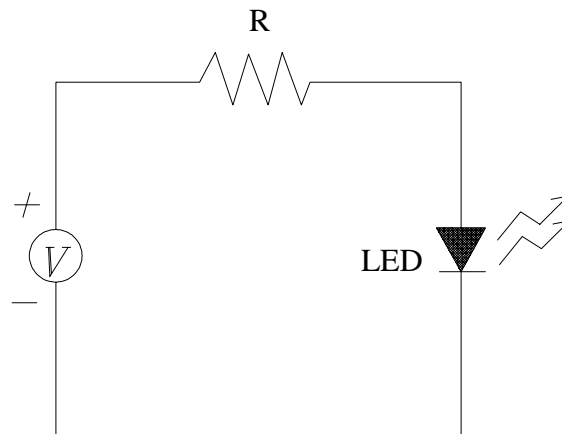

■ **Precautions For Use :**

1. Over-current-proof

Customer must apply resistors for protection , otherwise slight voltage shift will cause big current change ( Burn out will happen ).

2. Storage time

2.1 The operation of temperature and R.H. are :  $5^{\circ}\text{C} \sim 35^{\circ}\text{C}$  , R.H.60%.

2.2 Once the package is opened, the products should be used within a week.

Otherwise, they should be keeping in a dampproof box with desiccants.

Considering the tape life , we suggest our customers to use our products within a year(from production date).

2.3 If opened more than one week in an atmosphere  $5^{\circ}\text{C} \sim 35^{\circ}\text{C}$  , R.H.60% , they should be treated at  $60^{\circ}\text{C} \pm 5^{\circ}\text{C}$  for 15hrs.

2.4 When you discover that the desiccant in the package has a pink color (normal = blue) , you should treat them in the same conditions as 2.3.

■ **Soldering heat reliability ( DIP ) :**

Please refer to the following figure :

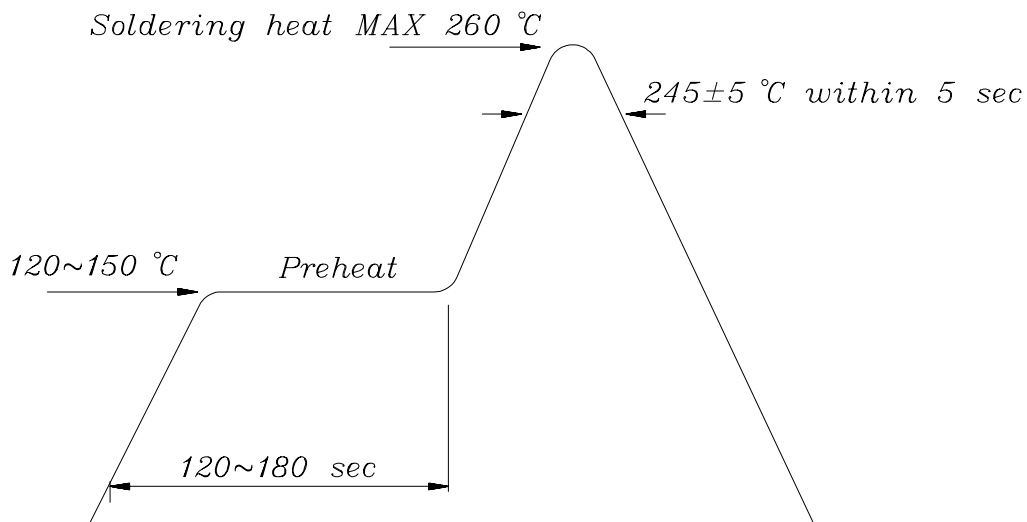

■ **Soldering Iron :**

Basic spec is  $\leq 5$  sec when  $260^{\circ}\text{C}$ . If temperature is higher, time should be shorter ( $+10^{\circ}\text{C} \rightarrow -1\text{sec}$ ). Power dissipation of iron should be smaller than 15 W , and temperature should be controllable. Surface temperature of the device should be under  $230^{\circ}\text{C}$ .

■ **Rework :**

1. Customer must finish rework within 5 sec under  $260^{\circ}\text{C}$ .
2. The head of iron can not touch copper foil.
3. Twin-head type is preferred.

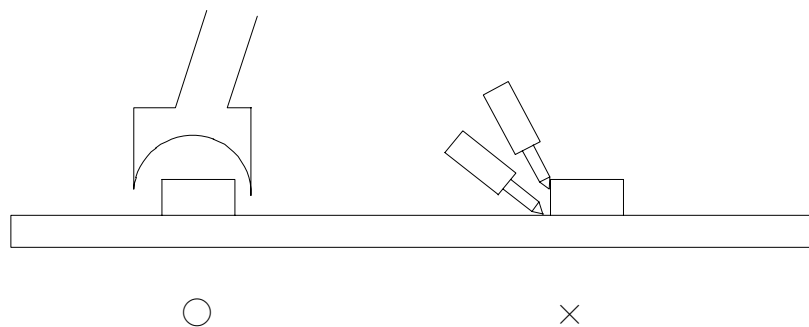



MODEL NO: 24-21UYC/S530-A2/TR8

Device Number : DSE-241-017 REV. 1.0

*Reverse Package Chip LED*

ECN : ..... Page: 8/8

■ Reflow Temp / Time :

