



## Technical Data Sheet

### Side View LEDs (Height 1.4mm)

#### 50-215UJC/XXXXXXXX/TR8

#### Features

- Side view white LED
- White SMT package
- Lead frame package with individual 2 pins
- Wide viewing angle
- Soldering methods: IR reflow soldering
- Pb-free
- The product itself will remain within RoHS compliant version.



#### Descriptions

- Due to the package design, 50-215 has wide viewing angle, low power consumption and white LEDs are devices that are materialized by combing blue chips and special phosphor. This feature makes the LED ideal for light guide application.

#### Applications

- LCD Back Light
- Mobile Phones
- Indicators
- Illuminations
- Switch Lights

#### Device Selection Guide

Chip	Emitted Color	Resin Color
Material		
GaN	Pure White	Water Clear

**Technical Data Sheet**

**Side View LEDs (Height 1.4mm)**

**50-215UJC/XXXXXXXX/TR8**

**Package Outline Dimensions**

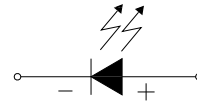
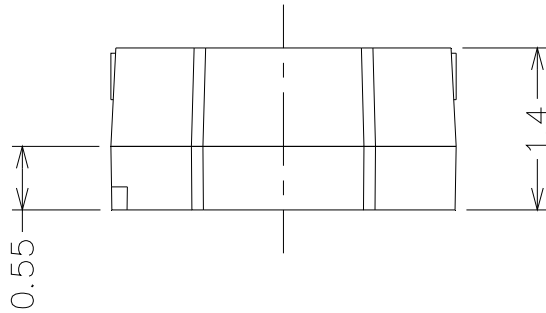

Polarity

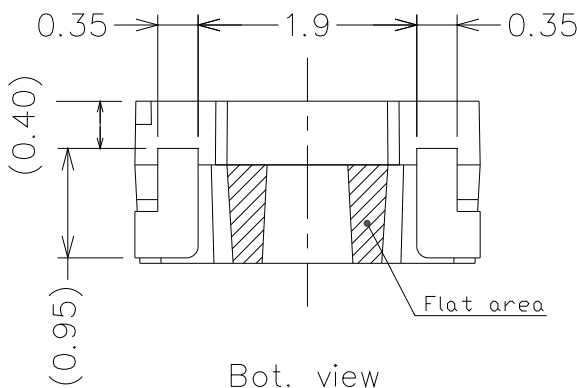
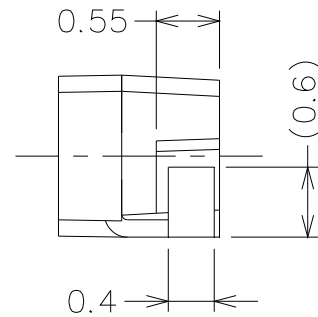
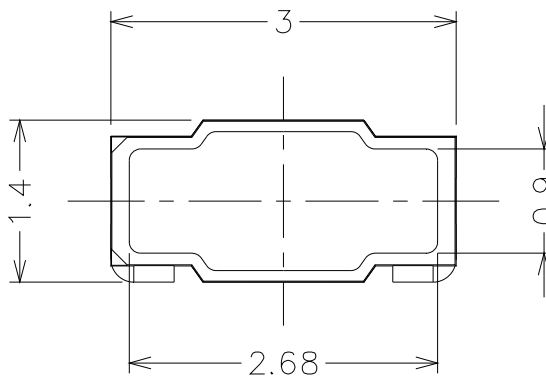

Bot. view

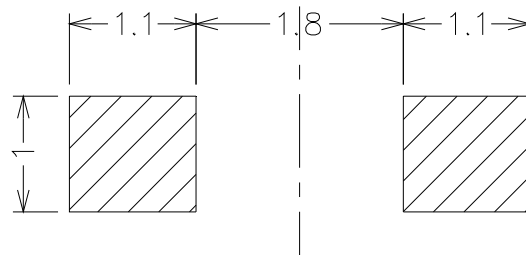

Soldering patterns

Note: The tolerances unless dimensions are  $\pm 0.1$ mm.

**Technical Data Sheet****Side View LEDs (Height 1.4mm)****50-215UJC/XXXXXXXX/TR8****Absolute Maximum Ratings (Ta=25°C)**

Parameter	Symbol	Rating	Unit
Reverse Voltage	V <sub>R</sub>	5	V
DC Forward Current	I <sub>F</sub>	30	mA
Pulse Forward Current (Duty 1/10 @1KHz)	I <sub>FP</sub>	100	mA
Electrostatic Discharge(HBM)* <sup>1</sup>	ESD	2000	V
LED Junction Temperature	T <sub>j</sub>	125	°C
Operating Temperature	T <sub>opr</sub>	-30 ~ +100	°C
Storage Temperature	T <sub>stg</sub>	-40 ~ +100	°C
Soldering Temperature	T <sub>sol</sub>	Reflow Soldering: 260°C for 10sec. Hand Soldering: 350°C for 3sec.	

Note\*<sup>1</sup>:

The products are sensitive to static electricity and must be carefully taken when handling products.

**Electro-Optical Characteristics (Ta=25°C)**

Parameter	Symbol	Min.	Typ.	Max.	Unit	Condition
Luminous Intensity	I <sub>V</sub>	1400	---	2200	mcd	I <sub>F</sub> =20mA
Viewing Angle	2θ <sub>1/2</sub>	---	120	---	deg	I <sub>F</sub> =20mA
Forward Voltage	V <sub>F</sub>	2.95	---	3.55	V	I <sub>F</sub> =20mA
Reverse Current	I <sub>R</sub>	---	---	50	μA	V <sub>R</sub> =5V

Notes:

1. Tolerance of Luminous Intensity: ± 11%
2. Tolerance of Forward Voltage: ± 0.05V

**Technical Data Sheet****Side View LEDs (Height 1.4mm)****50-215UJC/XXXXXXXX/TR8****Bin Range of Luminous Intensity**

Bin Code	Min.	Max.	Unit	Condition
26	1400	1450	mcd	I <sub>F</sub> =20mA
27	1450	1500		
28	1500	1550		
29	1550	1600		
30	1600	1650		
31	1650	1700		
32	1700	1750		
33	1750	1800		
34	1800	1850		
35	1850	1900		
36	1900	1950		
37	1950	2000		
38	2000	2050		
39	2050	2100		
40	2100	2150		
41	2150	2200		

Note: Tolerance of Luminous Intensity:  $\pm 11\%$



Technical Data Sheet

Side View LEDs (Height 1.4mm)

50-215UJC/XXXXXXXX/TR8

Bin Range of Forward Voltage

Group								Bin Code	Min.	Max.	Unit	Condition
0	1	2	3	4	5	6	7	6-1	2.95	3.05	V	I <sub>F</sub> =20mA
								6-2	3.05	3.15		
	8	7-1	3.15	3.25								
		7-2	3.25	3.35								
		8-1	3.35	3.45								
		8-2	3.45	3.55								

Group	Bin Code	Min.	Max.	Unit	Condition
9	6-11	3.00	3.05	V	I <sub>F</sub> =20mA
	6-2	3.05	3.15		
	7-1	3.15	3.25		
	7-2	3.25	3.35		
	8-1	3.35	3.45		
	8-11	3.45	3.50		

Group				Bin Code	Min.	Max.	Unit	Condition
B	C	E	F	5-2-3	2.90	3.00	V	I <sub>F</sub> =20mA
				6-1-3	3.00	3.10		
				6-2-3	3.10	3.20		
	7-1-3	3.20	3.30					
	7-2-3	3.30	3.40					
				8-1-3	3.40	3.50		

Note: Tolerance of Forward Voltage: ± 0.05V

**Technical Data Sheet****Side View LEDs (Height 1.4mm)****50-215UJC/XXXXXXXX/TR8****Bin Range of Chromaticity Coordinates Block (I<sub>F</sub>=20mA)**

Group	Range	I <sub>v</sub> Rank*	Group	Range	I <sub>v</sub> Rank*
01	B5-1,B5-2,B5-3,B5-4	40	26	A0-1, A0-3, A0-4	38
02	B5-1~B5-4,A0-2,A0-4	40	27	A0-1, A0-2, A0-3	38
07	B5-1,B5-3,A0-4	39	28	A0-2, A0-3, A0-4	38
08	A0-2,A0-3,A0-4	38	29	A0-2, B5-1, B5-3	39
09	A0-1,A0-3,A0+4	37	30	A0-2, A0-4, B5-3	39
10	A0+1, A0+2, A0-1	37	31	B5-1, A0-2, A0-4	39
11	A0+2, A0-1, A0-2	38	32	B5-1, B5-3, A0-4	39
12	A0-1, A0-2, B5-1	39	33	B5-1, B5-2, B5-4	40
13	A0-2, B5-1, B5-2	40	34	B5-1, B5-3, B5-4	40
14	A0+3, A0+4, A0-3	37	35	B5-1, B5-2, B5-3	40
15	A0+4, A0-3, A0-4	38	36	B5-2, B5-3, B5-4	40
16	A0-3, A0-4, B5-3	39	37	B5-1, B5-2	40
17	A0-4, B5-3, B5-4	40	38	A0-1, A0-3	37
18	A0+1, A0+2, A0+4	36	39	A0-2, A0-4, B5-1, B5-3	39
19	A0+1, A0+3, A0+4	36	40	A0-3,A0-4	38
20	A0+1, A0+2, A0+3	36	41	A0-4, B5-1, B5-3, B5-4	40
21	A0+2, A0-1, A0-3	37	42	A0-4, B5-3	39
22	A0+2, A0+4, A0-3	37	43	B5-2,B5-4	40
23	A0-1, A0+2, A0+4	37	44	A0-1, A0-2, A-4, B5-3	39
24	A0-1, A0-3, A0+4	37	45	B5-1, B5-3	39
25	A0-1, A0-2, A0-4	38	46	A0+1, A0+2	36

**Technical Data Sheet****Side View LEDs (Height 1.4mm)****50-215UJC/XXXXXXXX/TR8****Bin Range of Chromaticity Coordinates Block (I<sub>F</sub>=20mA)**

Group	Range	I <sub>V</sub> Rank*	Group	Range	I <sub>V</sub> Rank*
47	B6-1, B6-2, B6-3, B6-4	41	65	A0-2, A0-3, A0-4, B5-3	39
48	B6-2, B6-4	41	66	A0-3-1~A0-3-4, A0-4-1~A0-4-4	38
49	A0-2, B5-1, B5-3, B5-4	40	67	A0+2, A0-1, A0-3, A0-4	38
50	A0-1~A0-4, B5-1~B5-4	40	68	A0+4-R, A0-3, A0-4-L	38
51	A0-1, A0-3, A0-4-1, A0-4-3	38	69	B5-1, 2, 3, 4 subdivision	40
52	A0+3, A0+4	36	70	A0+4-2, A0+4-4, A0-3 subdivision, A0-4-1, A0-4-3	38
53	B6-1, B6-2, B6-3	41	71	A0-3 non-division, A0-4 subdivision	38
54	B6-1, B6-3	41	72	A0+1~+4, A0-1~-4, B5-1~-4, B6-1~-4	41
55	B5-2, B5-4, B6-1, B6-3	41	73	A0-4, B5-1, B5-3 subdivision	39
56	B5-2, B6-1	41	74	A0-4	38
57	A0-2, B5-1	39	75	B5-2	40
58	A0-1, A0-2	38	76	A0-1~A0-4; B5-1~B5-4	40
59	A0-1, A0-2, A0-3, A0-4, B5-1	39	77	B5-3, B5-4 subdivision	40
60	A0+2, A0+4, A0-1, A0-3	37	78	A0-3, A0+4	37
61	B5-2-1~B5-2-4, 6-1-1~B6-1-4	41	79	B5-1, B5-2, B5-3, B5-4, B6-3 subdivision	41
62	B5-3, B5-4	40	80	A0-3, A0-4, B5-3 subdivision	39
63	A0-1~A0-4, B5-1, B5-3	39	81	A0-3, A0-4, B5-3 divide into 8 parts (each)	39
64	A0-2, A0-4	38	82	A0-1~A0-4, A0+2, A0+4	38

**Technical Data Sheet****Side View LEDs (Height 1.4mm)****50-215UJC/XXXXXXXX/TR8****Bin Range of Chromaticity Coordinates Block (I<sub>F</sub>=20mA)**

Group	Range	I <sub>V</sub> Rank*	Group	Range	I <sub>V</sub> Rank*
83	B5-4, B6-3	41	C	A0-1,A0-2,A0-3,A0-4	38
84	B6-1, B6-2	41			
85	A0-4, B5-2, B5-3, B5-4	40			
86	B5 & B6 subdivision	41			
87	B5-3	39			
88	B5-2-3/ B5-2-4/ B5-4 subdivision/ B6-1-2/ B6-1-3/ B6-1-4/ B6-3 subdivision/ B6-4-1	41			
89	A0-4, B5-3 subdivision	39			
90	A0-4-R, B5-3 subdivision	39			
91	A0-3-2, A0-3-4, A0-4 subdivision, B5-3-1,B5-3-3	39			
92	B5-2 , B6-1-1, B6-4-1, B5-3-2, B6-1-3, B6-4-3, B6-1-4, B6-4-4, B5-4, B6-3	41			
93	A0+4, A0-3 subdivision	37			
94	A0-4-R, B5-3, B5-4 subdivision	40			
95	B5-4, B6-3 subdivision	41			
96	A0-4, B5-3, B5-4 subdivision	40			
A	A0+1, A0+2, A0+3, A0+4	36			
B	A0+4, A0-3, A0-4	38			

**Note:** The I<sub>V</sub> rank is the highest one for relative bin range of chromaticity coordinates.





Technical Data Sheet

Side View LEDs (Height 1.4mm)

50-215UJC/XXXXXXXX/TR8

The C.I.E. 1931 Chromaticity Diagram

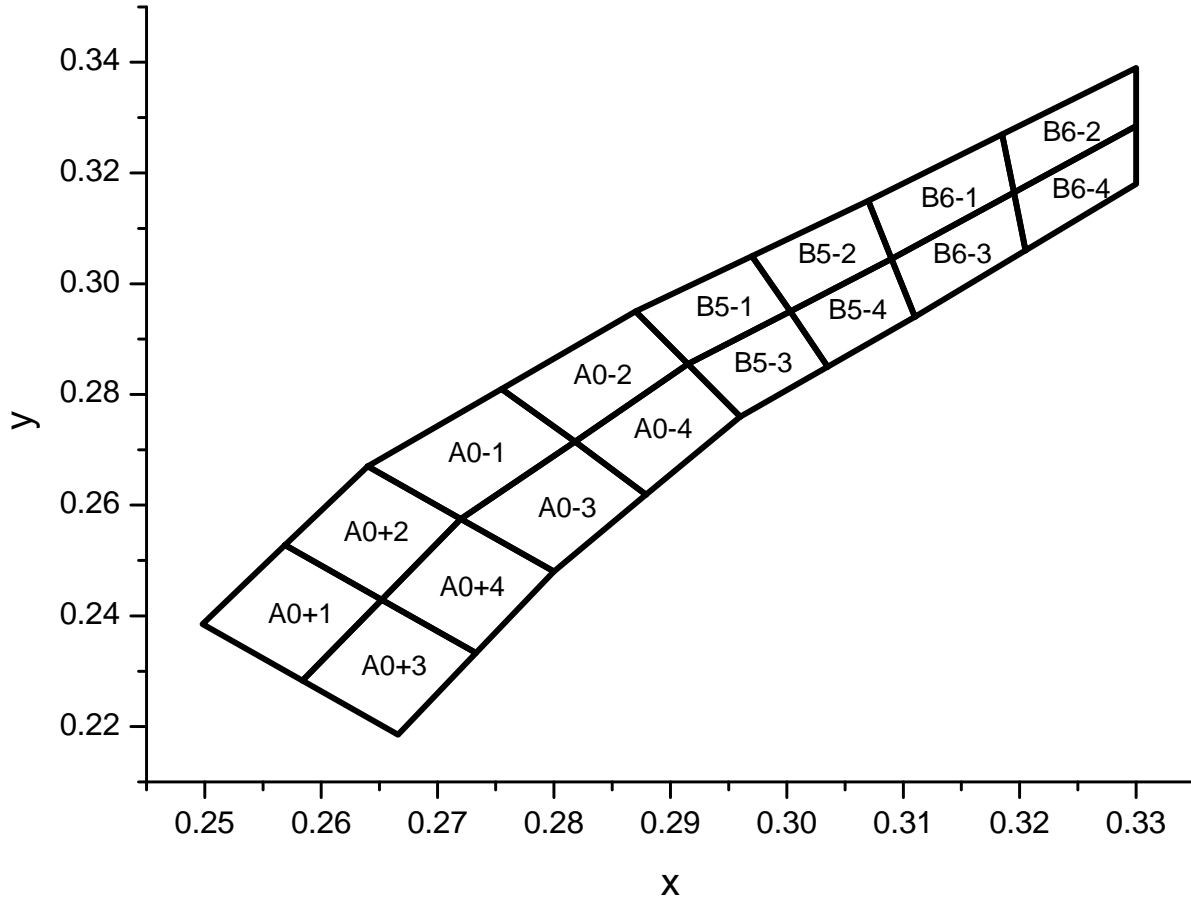



Technical Data Sheet

Side View LEDs (Height 1.4mm)

50-215UJC/XXXXXXXX/TR8

Chromaticity Coordinates of Bin Code

Bin Code	CIE_x	CIE_y	Bin Code	CIE_x	CIE_y
A0+1	0.2569	0.2528	A0+3	0.2652	0.2429
	0.2498	0.2385		0.2584	0.2283
	0.2584	0.2283		0.2666	0.2185
	0.2652	0.2429		0.2733	0.2333
A0+2	0.2640	0.2670	A0+4	0.2720	0.2575
	0.2569	0.2528		0.2652	0.2429
	0.2652	0.2429		0.2733	0.2333
	0.2720	0.2575		0.2800	0.2480
A0-1	0.2720	0.2575	A0-3	0.2800	0.2480
	0.2640	0.2670		0.2720	0.2575
	0.2755	0.2810		0.2818	0.2715
	0.2818	0.2715		0.2879	0.2619
A0-2	0.2818	0.2715	A0-4	0.2879	0.2619
	0.2755	0.2810		0.2818	0.2715
	0.2870	0.2950		0.2915	0.2855
	0.2915	0.2855		0.2960	0.2760

Note: Tolerance of Chromaticity Coordinates: ±0.01



Technical Data Sheet

Side View LEDs (Height 1.4mm)

50-215UJC/XXXXXXXX/TR8

Chromaticity Coordinates of Bin Code

Bin Code	CIE_x	CIE_y	Bin Code	CIE_x	CIE_y
B5-1	0.2915	0.2855	B5-3	0.2960	0.2760
	0.2870	0.2950		0.2915	0.2855
	0.2970	0.3050		0.3003	0.2950
	0.3003	0.2950		0.3035	0.2850
B5-2	0.3003	0.2950	B5-4	0.3035	0.2850
	0.2970	0.3050		0.3003	0.2950
	0.3070	0.3150		0.3090	0.3045
	0.3090	0.3045		0.3110	0.2940
B6-1	0.3090	0.3045	B6-3	0.3110	0.2940
	0.3070	0.3150		0.3090	0.3045
	0.3185	0.3270		0.3195	0.3165
	0.3195	0.3165		0.3205	0.3060
B6-2	0.3195	0.3165	B6-4	0.3205	0.3060
	0.3185	0.3270		0.3195	0.3165
	0.3300	0.3390		0.3300	0.3285
	0.3300	0.3285		0.3300	0.3180

Note: Tolerance of Chromaticity Coordinates: ±0.01

**Technical Data Sheet**

**Side View LEDs (Height 1.4mm)**

**50-215UJC/XXXXXXXX/TR8**

**Typical Electro-Optical Characteristics Curves**

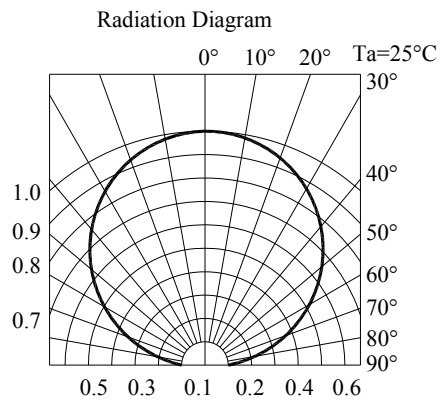
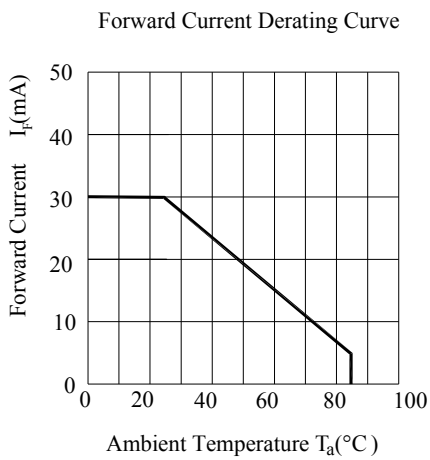
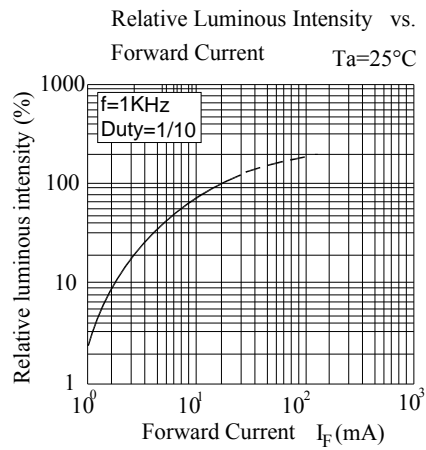
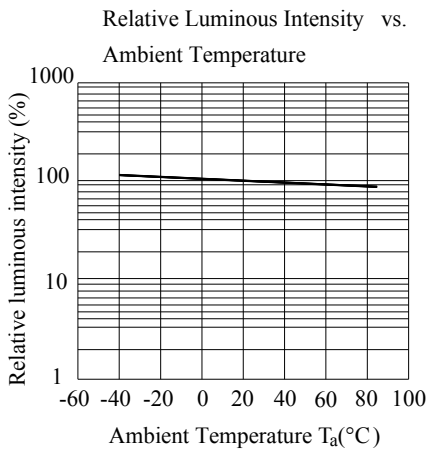
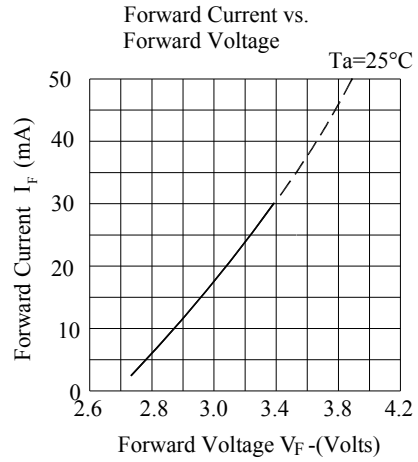
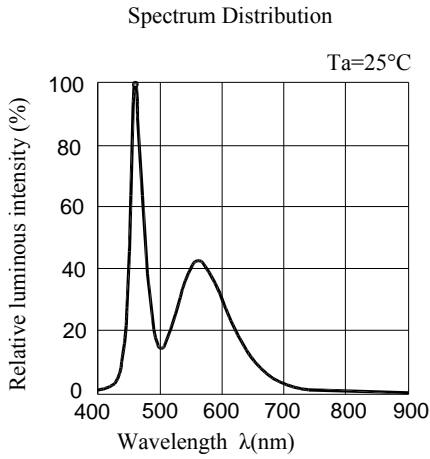



Technical Data Sheet

Side View LEDs (Height 1.4mm)

**50-215UJC/XXXXXXXX/TR8**

Label Explanation

- CAT: Luminous Intensity Rank
- HUE: Chromaticity Coordinates
- REF: Forward Voltage Rank



Reel Dimensions

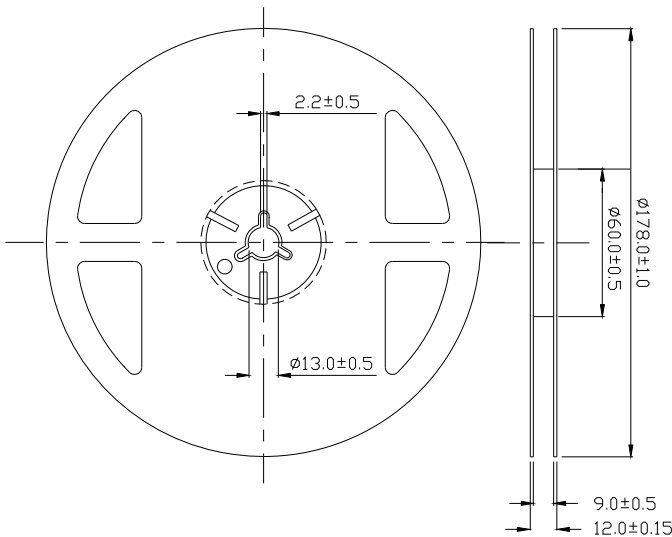

Note: The tolerances unless dimensions are ± 0.1mm.

**Technical Data Sheet**

**Side View LEDs (Height 1.4mm)**

**50-215UJC/XXXXXXXX/TR8**

**Carrier Tape Dimensions: Loaded Quantity 2000 pcs. Per Reel**

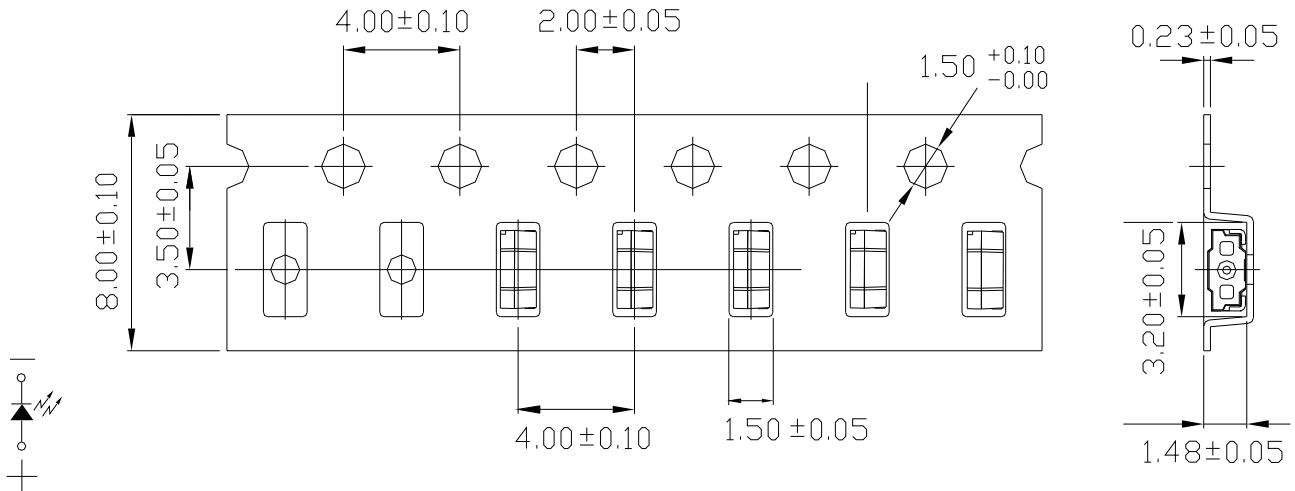

Note: The tolerances unless dimensions are  $\pm 0.1$ mm.

**Moisture Resistant Packaging**

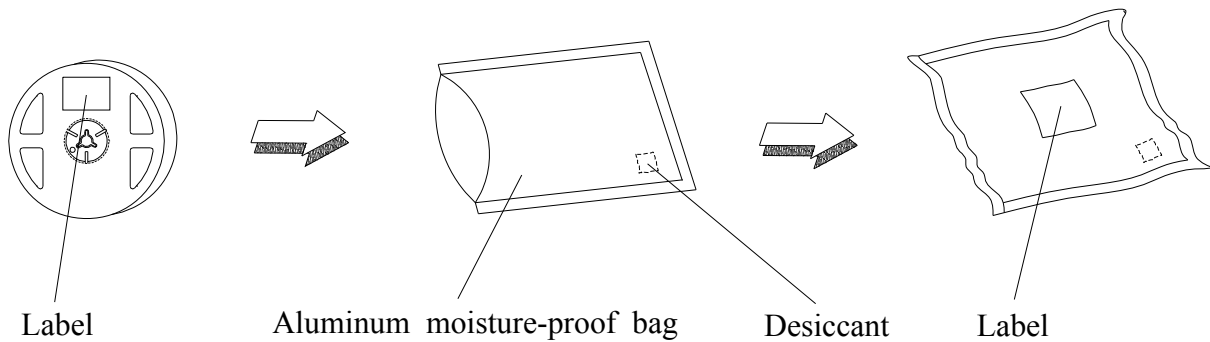

**Technical Data Sheet****Side View LEDs (Height 1.4mm)****50-215UJC/XXXXXXXX/TR8****Reliability Test Items and Conditions**

The reliability of products shall be satisfied with items listed below.

Confidence level: 90%

LTPD: 10%

No.	Items	Test Condition	Test Hours/Cycles	Sample Qty'	Ac/Re
1	Reflow Soldering	Temp.: 260°C±5°C Min. 5 sec.	6 Min.	22 pcs.	0/1
2	Temperature Cycle	H: +100°C 15min. ↓ 5 min. L: -40°C 15min.	300 cycles	22 pcs.	0/1
3	Thermal Shock	H: +100°C 5min. ↓ 10 sec. L: -10°C 5min.	300 cycles	22 pcs.	0/1
4	High Temperature Storage	Temp.: 100°C±5°C	1000 hrs.	22 pcs.	0/1
5	Low Temperature Storage	Temp.: -40°C±5°C	1000 hrs.	22 pcs.	0/1
6	DC Operating Life	I <sub>F</sub> = 20 mA / 25°C	1000 hrs.	22 pcs.	0/1
7	High Temperature / High Humidity	85°C±5°C / 85%RH	1000 hrs.	22 pcs.	0/1

**Technical Data Sheet****Side View LEDs (Height 1.4mm)****50-215UJC/XXXXXXXX/TR8****Precautions for Use**

## 1. Over-current-proof

Customer must apply resistors for protection; otherwise slight voltage shift will cause big current change (Burn out will happen).

## 2. Storage

2.1 Don't open moisture proof bag before the products are ready to use.

2.2 Before opening the package: The LEDs should be kept at 30°C or less and 90%RH or less.

2.3 After opening the package: The LED's floor life is 1 year under 30°C or less and 60% RH or less. If unused LEDs remain, it should be stored in moisture proof packages.

2.4 If the moisture absorbent material (silica gel) has faded away or the LEDs have exceeded the storage time, baking treatment should be performed using the following conditions.

baking treatment: 60±5°C for 24 hours

## 3. Soldering Condition

## 3.1 Pb-free solder temperature profile:

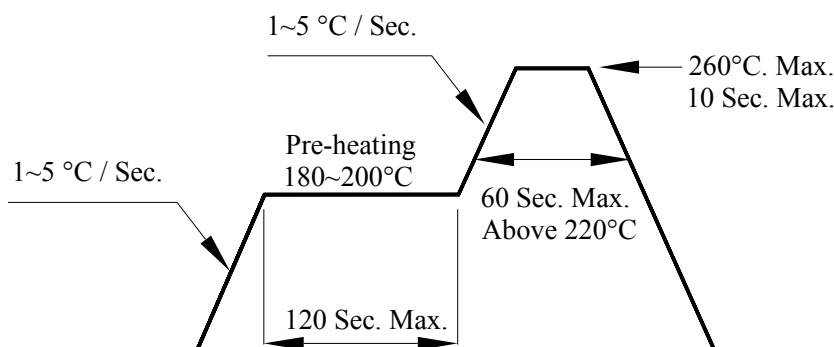

3.2 Reflow soldering should not be done more than two times.

3.3 When soldering, do not put stress on the LEDs during heating.

3.4 After soldering, do not warp the circuit board.



**Technical Data Sheet****Side View LEDs (Height 1.4mm)****50-215UJC/XXXXXXXX/TR8****4. Soldering Iron**

Each terminal is to go to the tip of soldering iron temperature less than 350°C for 3 seconds within once in less than the soldering iron capacity 25W. Leave two seconds and more intervals, and do soldering of each terminal. Be careful because the damage of the product is often started at the time of the hand solder.

**5. Repairing**

Repair should not be done after the LEDs have been soldered. When repairing is unavoidable, a double-head soldering iron should be used (as below figure). It should be confirmed beforehand whether the characteristics of the LEDs will or will not be damaged by repairing.

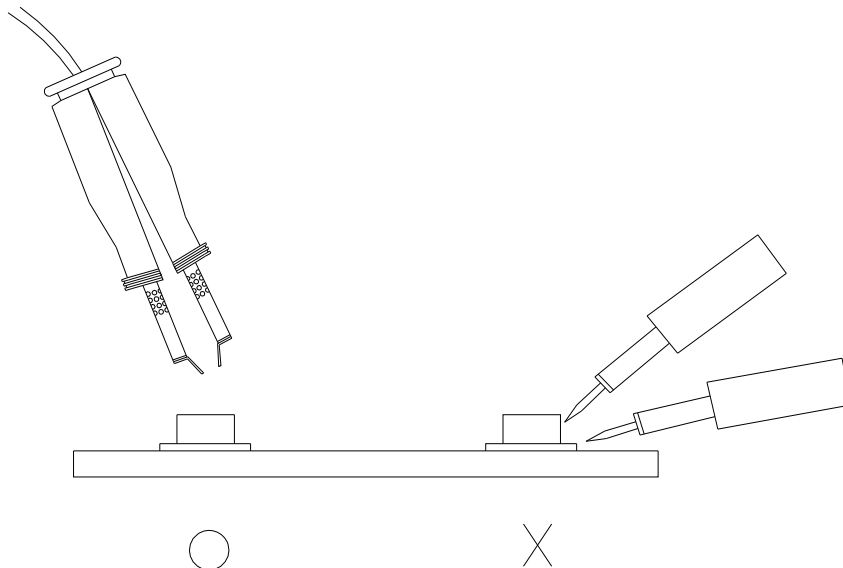

**EVERLIGHT ELECTRONICS CO., LTD.**  
Office: No 25, Lane 76, Sec 3, Chung Yang Rd,  
Tucheng, Taipei 236, Taiwan, R.O.C

Tel: 886-2-2267-2000, 2267-9936  
Fax: 886-2267-6244, 2267-6189, 2267-6306  
<http://www.everlight.com>