

IRR60-48C/TR8

Features

- Compatible with infrared and vapor phase reflow solder process.
- Compatible with automatic placement equipment.
- Bi-color LED wavelength. (660nm, 905nm)
- Pb free
- The product itself will remain within RoHS compliant version.

Descriptions

- IRR60-48C/TR8 is an infrared emitting diode in miniature SMD package which is molded in a water clear plastic with flat top view lens.
The device is spectrally matched with silicon photodiode and phototransistor.

Applications

- Sensor
- Oximeter

Device Selection Guide

LED Part No.	Chip	Lens Color
	Material	
IRR60-48C/TR8	GaAlAs	Water clear

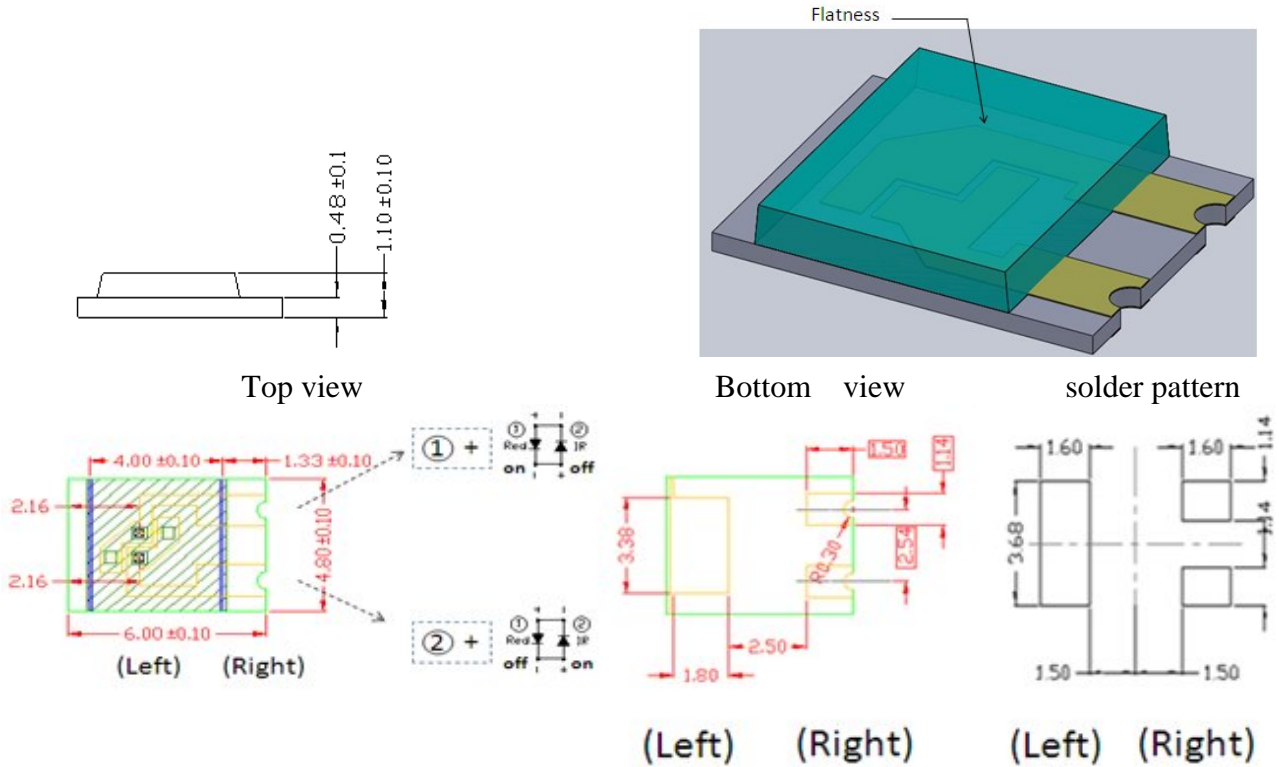

Notes: 1.All dimensions are in millimeters
2.Tolerances unless dimensions ± 0.1 mm

Absolute Maximum Ratings (Ta=25)

Parameter	Symbol	Rating		Unit
		660nm(Red)	905nm(IR)	
Continuous Forward Current	I_F	50		mA
Peak Forward Current *1	I_{FP}	500		mA
Reverse Voltage	V_R	5		V
Operating Temperature	T_{opr}	-25~ +85		
Storage Temperature	T_{stg}	-25~ +85		
Soldering Temperature *3	T_{sol}	260		
Power Dissipation at(or below) 25 Free Air Temperature	P_d	110	80	mW
Temperature resistance junction ambient	R_{thj-a}	550		K/W

Notes: *1: I_{FP} Conditions--Pulse Width 100 μ s and Duty 1%.

*2:Soldering time 5 seconds.

Electro-Optical Characteristics (Ta=25)

Parameter	Symbol	Condition	Min.	Typ.	Max.	Unit	
Radiant Intensity	I _E	Red	I _F =20mA	0.5	1.6	--	mW /sr
		IR		0.5	0.9	--	
Peak Wavelength	p	Red	I _F =20mA	657	660	663	nm
		IR		895	905	915	
Spectral Bandwidth		Red	I _F =20mA	--	20	--	nm
		IR		--	60	--	
Forward Voltage	V _F	Red	I _F =20mA	2.0	2.2	2.6	V
		IR		1.2	1.4	1.8	
Reverse Current	I _R	Red	V _R =5V	--	--	10	μ A
		IR		--	--	10	
View Angle	2 1/2	Red	I _F =20mA	--	125	--	deg
		IR		--	145	--	

Typical Electro-Optical Characteristics Curves

Fig.1 Forward Current vs.
Ambient Temperature

Red

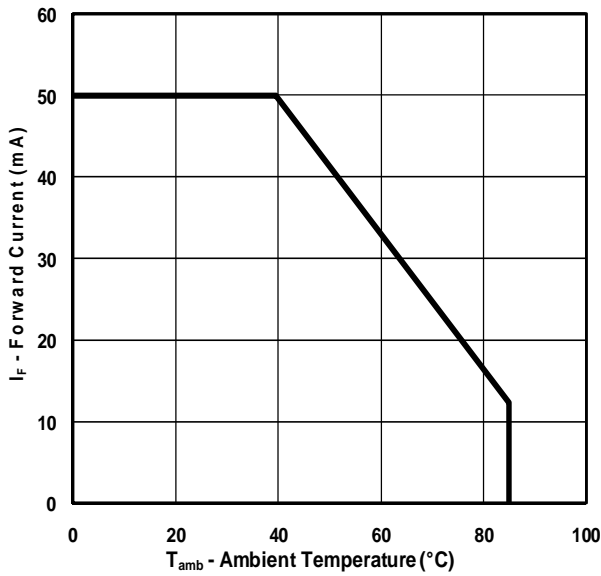

IR

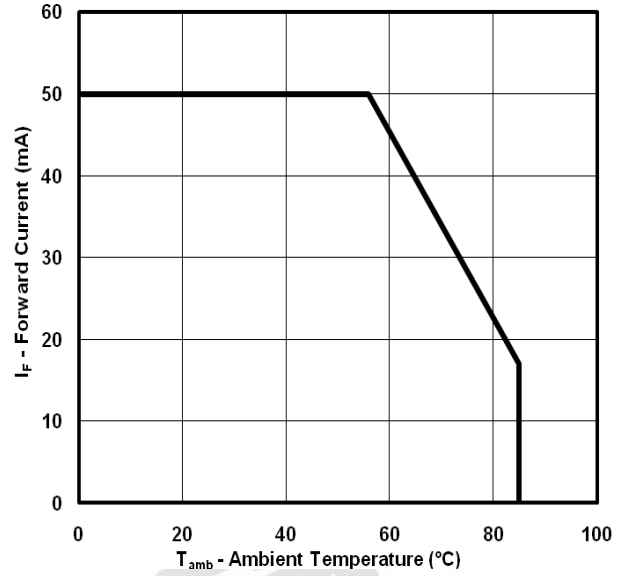
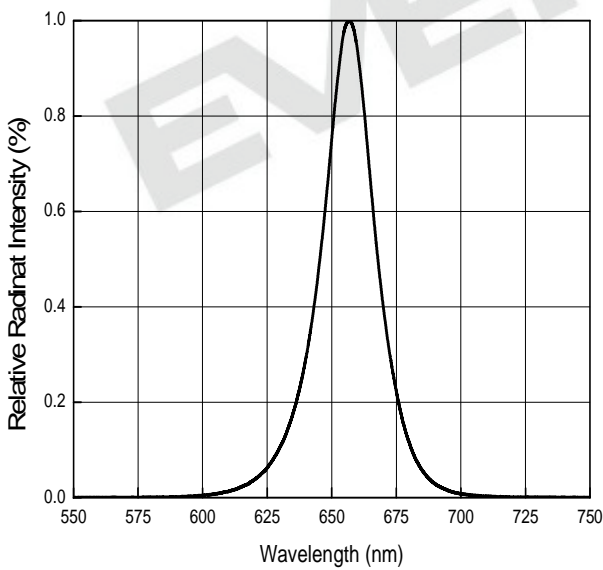
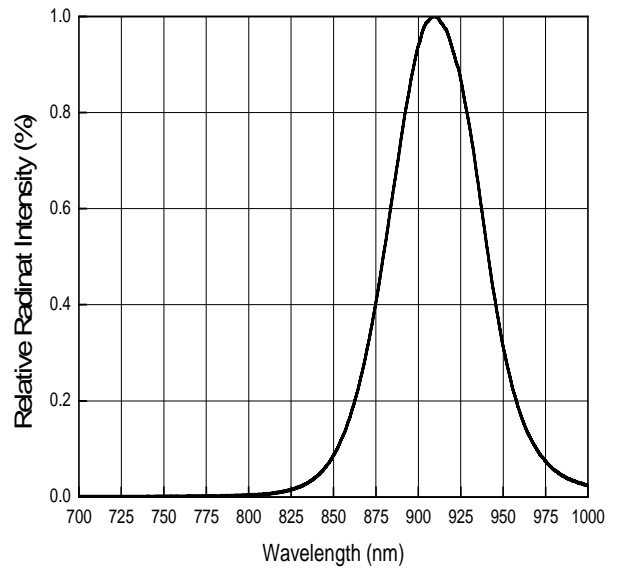

Fig.2 Spectral Distribution

Red



IR



Typical Electro-Optical Characteristics Curves

Fig.3 Radiant Intensity vs.
Forward Current

Red

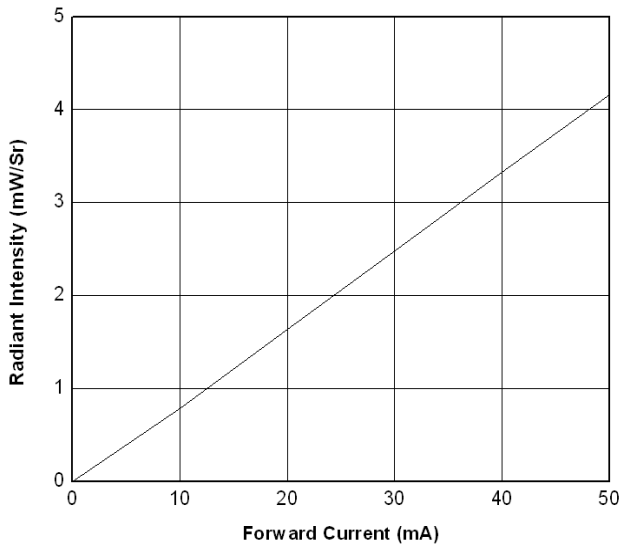

IR

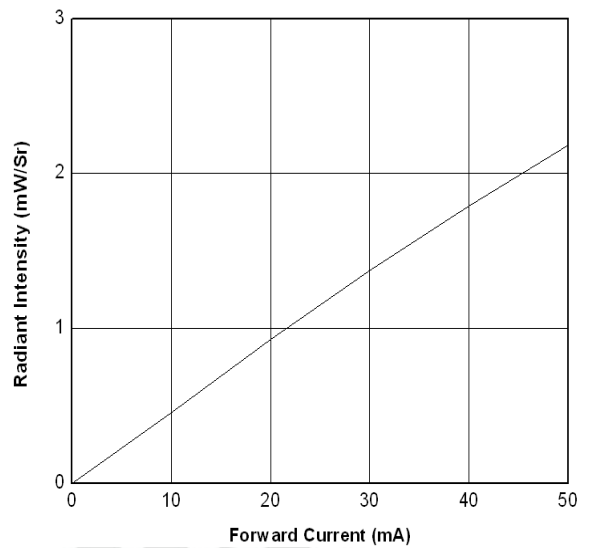
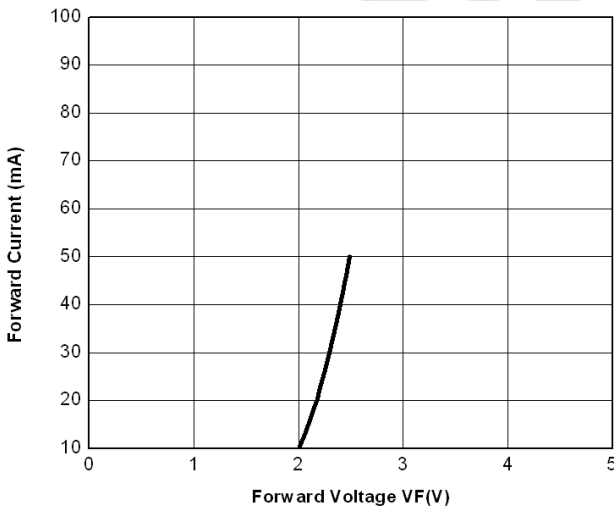
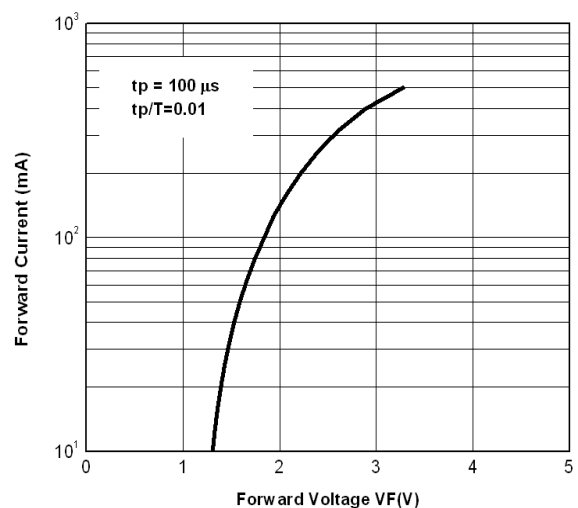

Fig.4 Forward Current vs.
Forward Voltage

Red



IR



Typical Electro-Optical Characteristics Curves

Fig.5 Relative Radiant Intensity vs.
Angular Displacement

Red

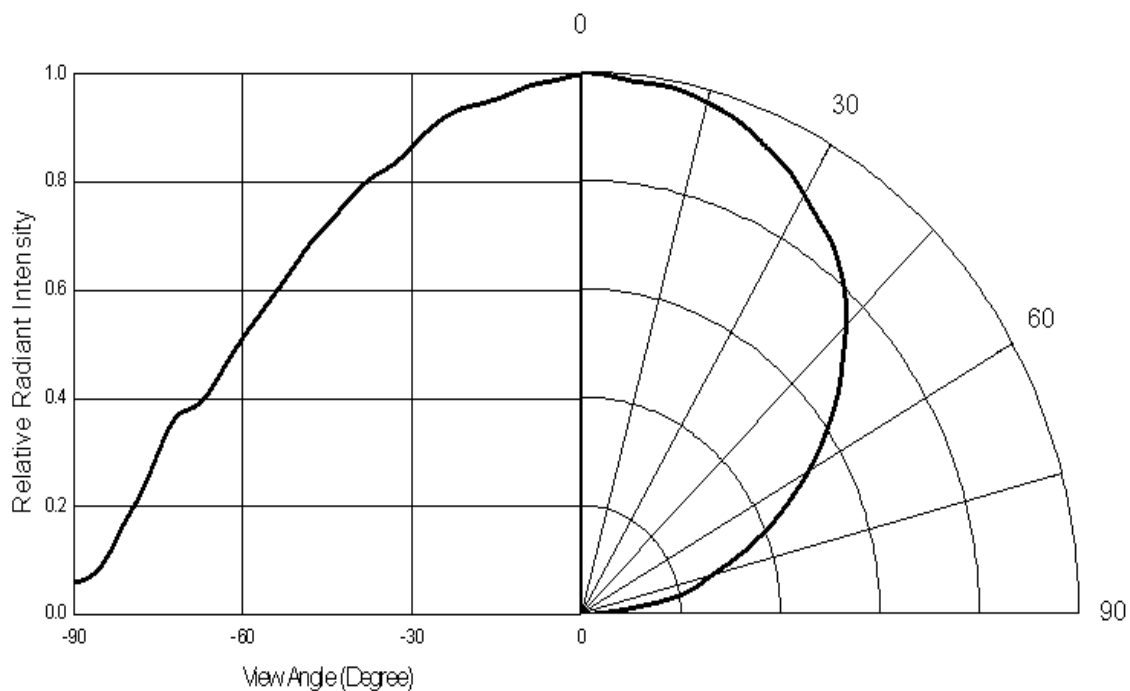

IR

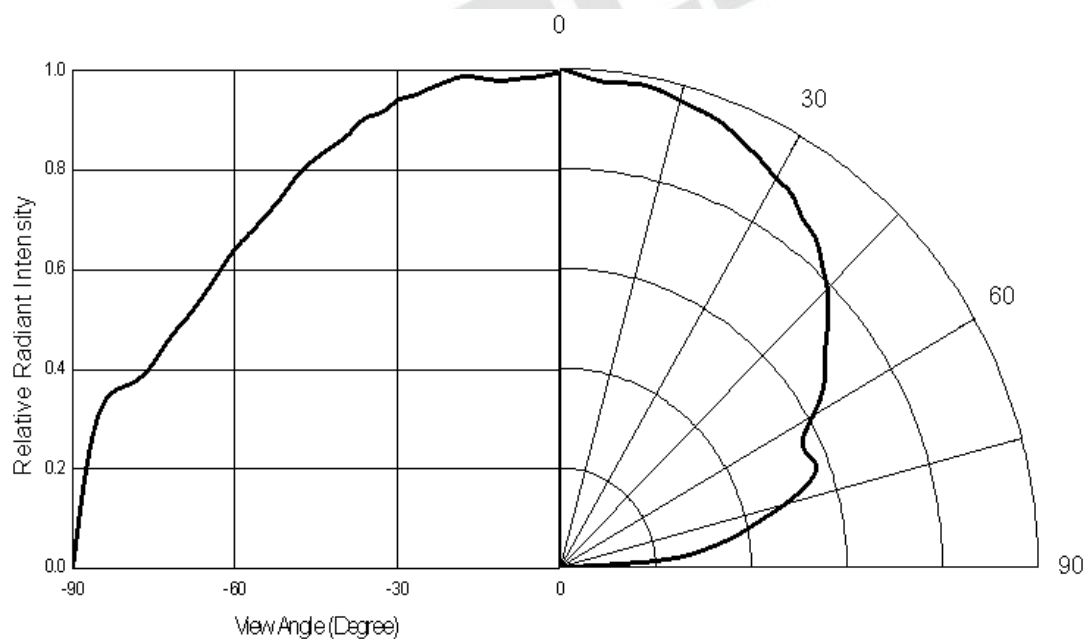

Precautions For Use

1. Over-current-proof

Customer must apply resistors for protection , otherwise slight voltage shift will cause big current change (Burn out will happen).

2. Storage

2.1 Do not open moisture proof bag before the products are ready to use.

2.2 Before opening the package, the LEDs should be kept at 30% or less and 90%RH or less.

2.3 The LEDs should be used within a year.

2.4 After opening the package, the LEDs should be kept at 30% or less and 70%RH or less.

2.5 The LEDs should be used within 72hours (3days) after opening the package.

2.6 If the moisture absorbent material (silica gel) has faded away or the LEDs have exceeded the storage time, baking treatment should be performed using the following conditions.

Baking treatment : 60 ± 5 for 24 hours.

3. Soldering Condition

3.1 Pb-free solder temperature profile

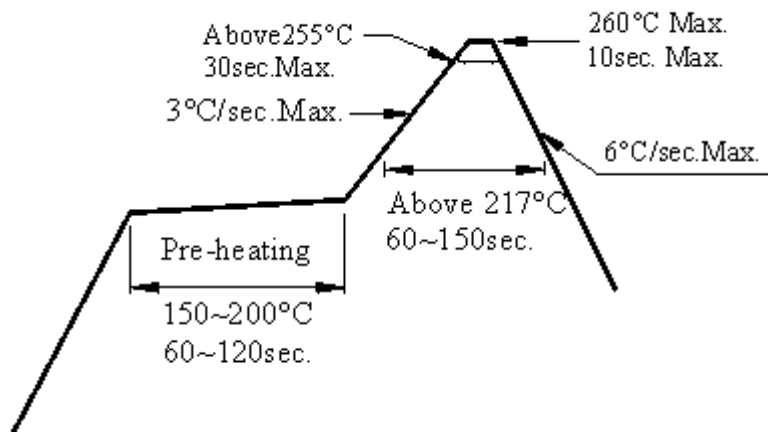

3.2 Reflow soldering should not be done more than two times.

3.3 When soldering, do not put stress on the LEDs during heating.

3.4 After soldering, do not warp the circuit board.

4.Soldering Iron

Each terminal is to go to the tip of soldering iron temperature less than 350 for 3 seconds within once in less than the soldering iron capacity 25W. Leave two seconds and more intervals, and do soldering of each terminal. Be careful because the damage of the product is often started at the time of the hand solder.

5.Repairing

Repair should not be done after the LEDs have been soldered. When repairing is unavoidable, a double-head soldering iron should be used (as below figure). It should be confirmed beforehand whether the characteristics of the LEDs will or will not be damaged by repairing.

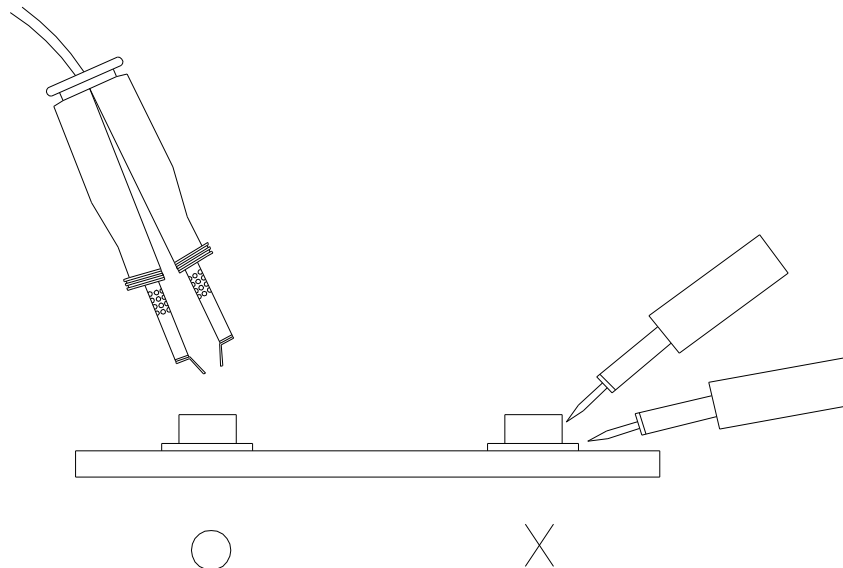

Package Dimensions

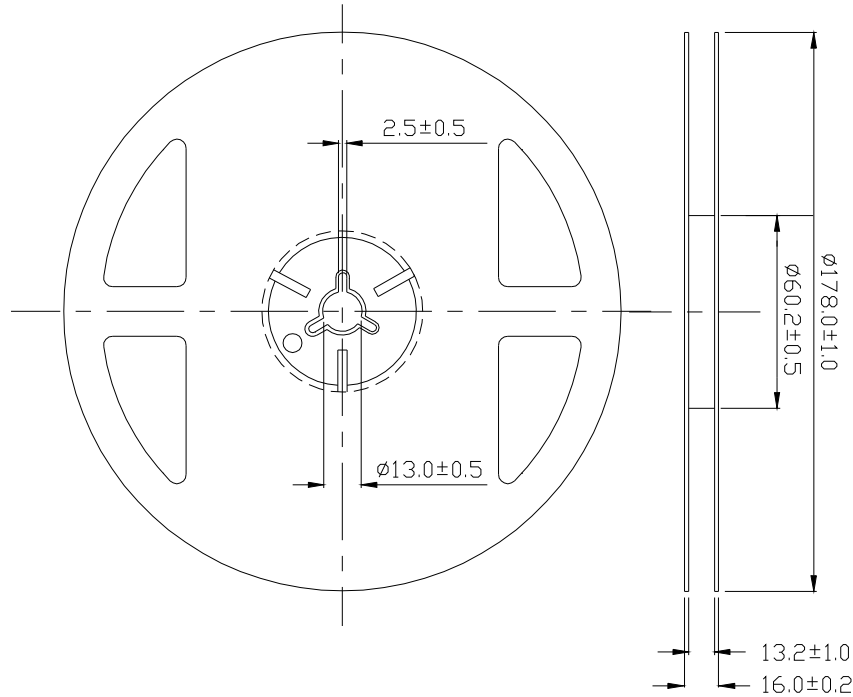

Carrier Tape Dimensions: Loaded quantity 1000 PCS per reel.

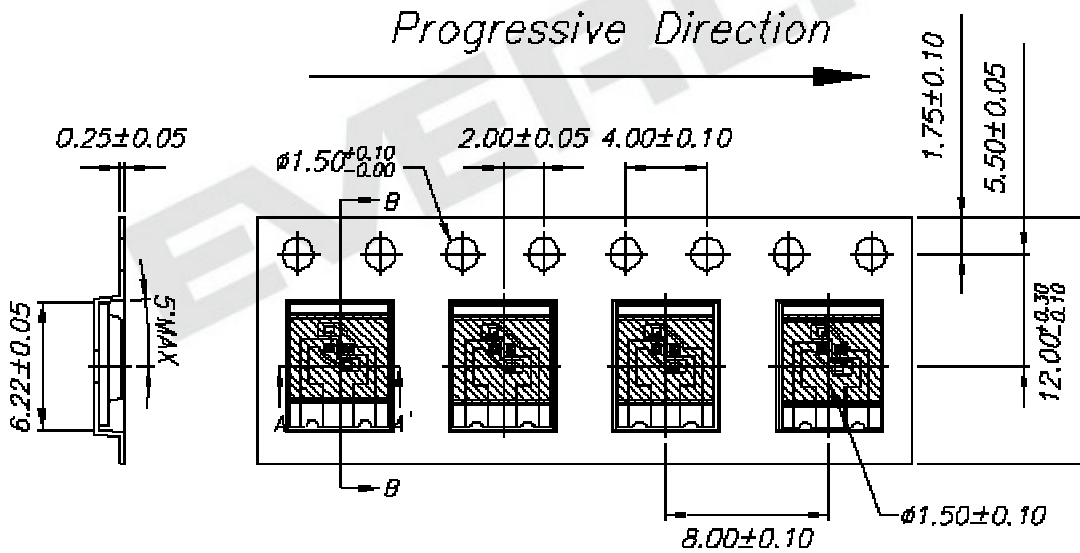

- Note: 1. Dimensions are in millimeters
2. The tolerances unless mentioned is $\pm 0.1\text{mm}$

Moisture Resistant Packaging

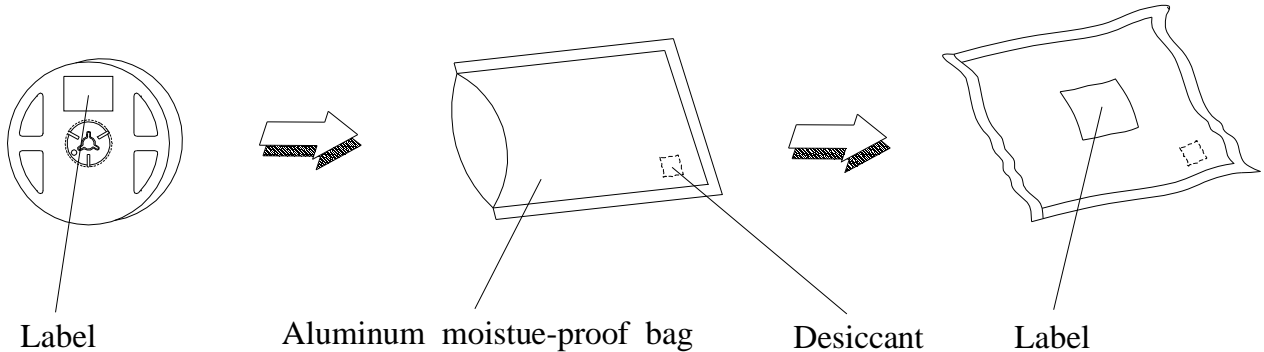

Label Form Specification

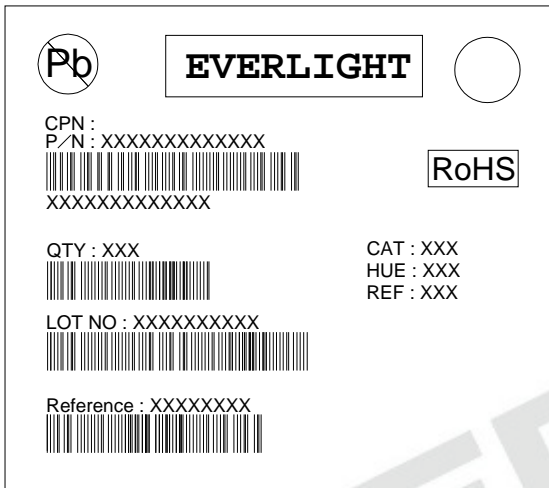

CPN: Customer's Production Number
P/N : Production Number
QTY: Packing Quantity
CAT: Ranks
HUE: Peak Wavelength
REF: Reference
LOT No: Lot Number
MADE IN TAIWAN: Production Place

Notes

1. Above specification may be changed without notice. EVERLIGHT will reserve authority on material change for above specification.
2. When using this product, please observe the absolute maximum ratings and the instructions for using outlined in these specification sheets. EVERLIGHT assumes no responsibility for any damage resulting from use of the product which does not comply with the absolute maximum ratings and the instructions included in these specification sheets.
3. These specification sheets include materials protected under copyright of EVERLIGHT corporation. Please don't reproduce or cause anyone to reproduce them without EVERLIGHT's consent.