



LED Display Product Data Sheet LTG-0122M

Spec No.: DS30-2001-166

Effective Date: 10/04/2002

Revision: A

LITE-ON DCC

RELEASE

BNS-OD-FC001/A4

LITEON LITE-ON TECHNOLOGY CORPORATION

Property of LITE-ON Only

FEATURES

- * 0.24 inch (6 mm) DIGIT HEIGHT
- * CONTINUOUS UNIFORM SEGMENTS
- * LOW POWER REQUIREMENT
- * EXCELLENT CHARACTERS APPEARANCE
- * HIGH BRIGHTNESS & HIGH CONTRAST
- * WIDE VIEWING ANGLE
- * SOLID STATE RELIABILITY

DESCRIPTION

The LTG-0122M is a 0.24 inch (6 mm) digit height 6 digit seven-segment display. The device is multi-color applicable display. The GREEN LED chips, which are made from GaP on GaP substrate and RED ORANGE LED chips, which are made from GaAsP on GaP. The device has a black face and white segments.

DEVICE

PART NO.	DESCRIPTION
GREEN & RED ORANGE	Multiplex Common Anode
LTG-0122M	

LITEON LITE-ON TECHNOLOGY CORPORATION

Property of LITE-ON Only

PACKAGE DIMENSIONS

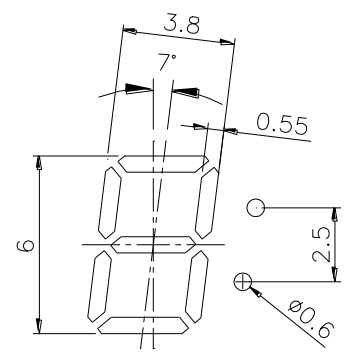
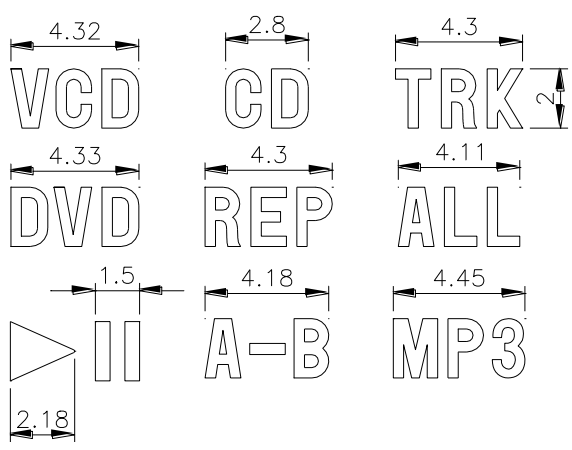
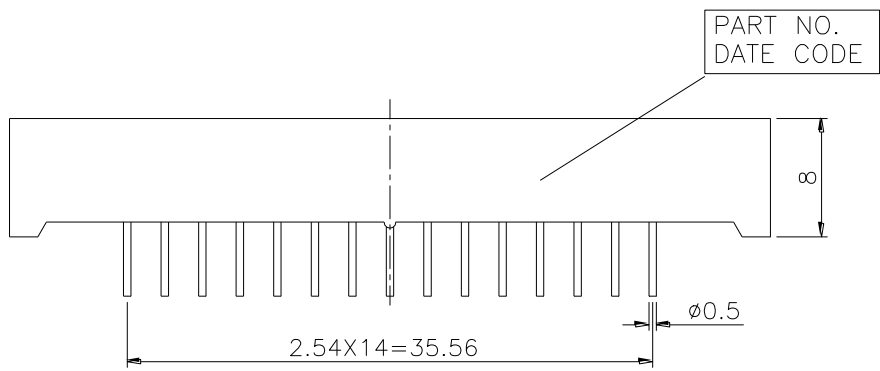
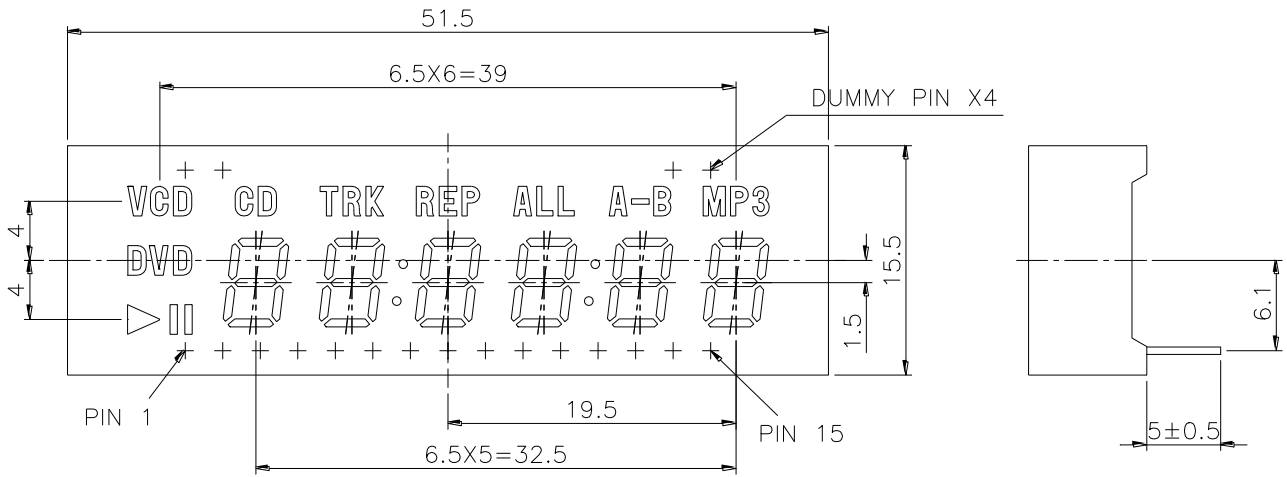

JAPAN PATENT:3075028

KOREA PATENT:0209198

NOTES: All dimensions are in millimeters. Tolerances are ± 0.25 mm unless otherwise noted.

INTERNAL CIRCUIT DIAGRAM

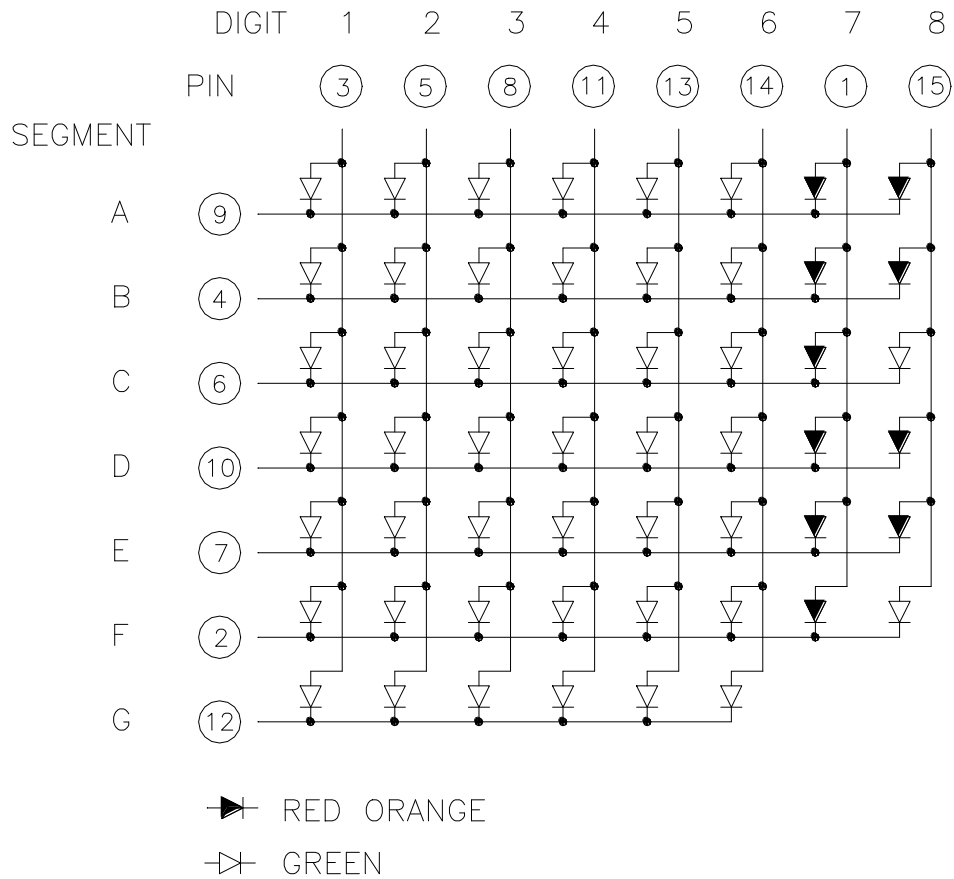
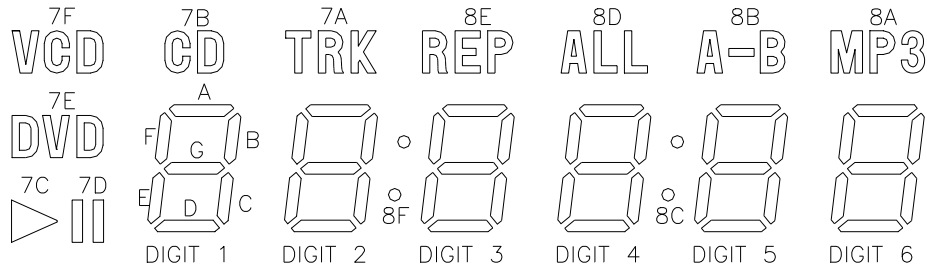

PIN CONNECTION

NO	CONNECTION
1	COMMON ANODE 7A~7F
2	CATHODE F
3	COMMON ANODE (DIGIT 1)
4	CATHODE B
5	COMMON ANODE (DIGIT 2)
6	CATHODE C
7	CATHODE E
8	COMMON ANODE (DIGIT 3)
9	CATHODE A
10	CATHODE D
11	COMMON ANODE (DIGIT 4)
12	CATHODE G
13	COMMON ANODE (DIGIT 5)
14	COMMON ANODE (DIGIT 6)
15	COMMON ANODE 8A~8F

LITEON LITE-ON TECHNOLOGY CORPORATION

Property of LITE-ON Only

ABSOLUTE MAXIMUM RATING

PARAMETER	GREEN	RED ORANGE	UNIT
Power Dissipation Per Chip	75	75	mW
Peak Forward Current Per Chip (Frequency 1Khz, 10% duty cycle)	100*	100*	mA
Continuous Forward Current Per Chip	25	25	mA
Derating Linear From 25°C Per Chip	0.33	0.33	mA/°C
Reverse Voltage Per Chip	5	5	V
Operating Temperature Range	-35°C to +85°C		
Storage Temperature Range	-35°C to +85°C		
Solder Temperature: max 260°C for max 3sec at 1.6mm below seating plane			

* see figure 5 to establish pulsed condition

ELECTRICAL / OPTICAL CHARACTERISTICS AT Ta=25°C

GREEN

PARAMETER	SYMBOL	MIN.	TYP.	MAX.	UNIT	TEST CONDITION
Average Luminous Intensity Per Segment	I _v	500	1600		μcd	I _F = 10mA
Peak Emission Wavelength	λ _p		565		nm	I _F = 20mA
Spectral Line Half-Width	Δλ		30		nm	I _F = 20mA
Dominant Wavelength	λ _d		569		nm	I _F = 20mA
Forward Voltage Per Chip	V _F		2.1	2.6	V	I _F = 10mA
Reverse Current Per Chip	I _R			100	μA	V _R = 5V
Luminous Intensity Matching Ratio	I _v -m			2:1		I _F = 10mA

RED ORANGE

PARAMETER	SYMBOL	MIN.	TYP.	MAX.	UNIT	TEST CONDITION
Average Luminous Sterance	I _v	500	1600		μcd	I _F = 10mA
Peak Emission Wavelength	λ _p		630		nm	I _F = 20mA
Spectral Line Half-Width	Δλ		40		nm	I _F = 20mA
Dominant Wavelength	λ _d		621		nm	I _F = 20mA
Forward Voltage Per Chip	V _F		2	2.6	V	I _F = 10mA
Reverse Current Per Chip	I _R			100	μA	V _R = 5V
Luminous Intensity Matching Ratio	I _v -m			2:1		I _F = 10mA

Note: Luminous intensity is measured with a light sensor and filter combination that approximates the CIE (Commision Internationale De L'Eclairage) eye-response curve.

TYPICAL ELECTRICAL / OPTICAL CHARACTERISTIC CURVES

(25°C Ambient Temperature Unless Otherwise Noted)

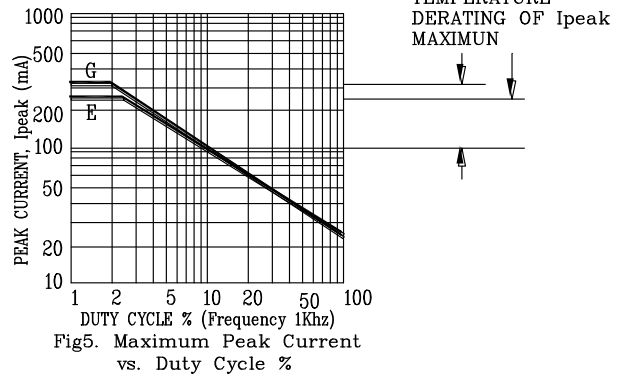
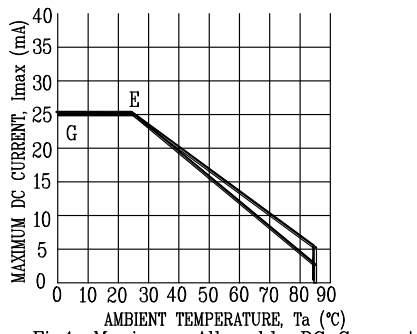
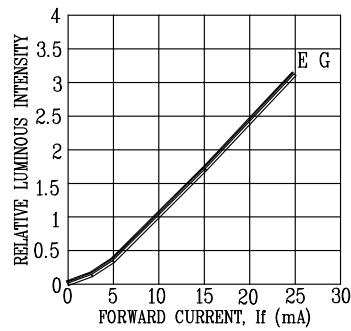
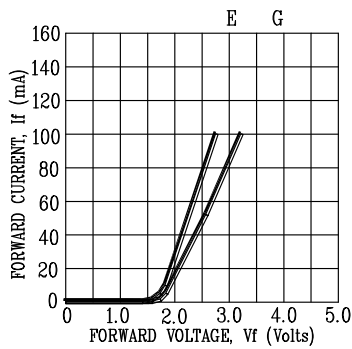
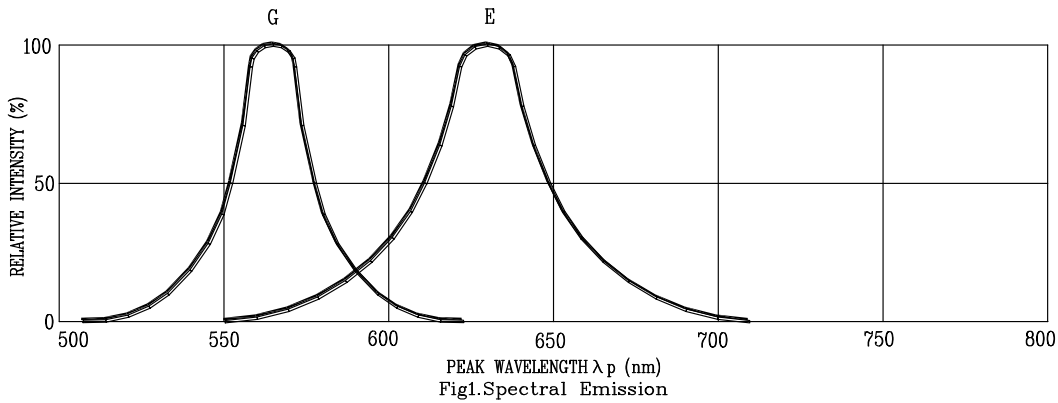

NOTE: G=GREEN E=RED ORANGE