

PART NUMBER	LDT-N4004RI-SI	REV.	A
DATE	E.C.N. NUMBER AND REVISION COMMENTS		REV.
07.31.12	E.C.N. #10BRDR. & REDRAWN.		A

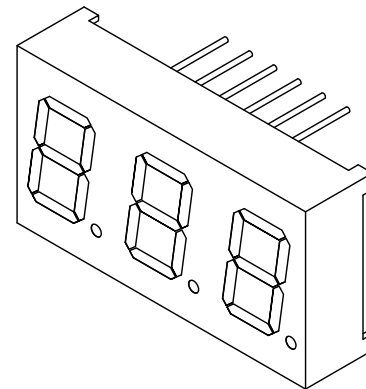
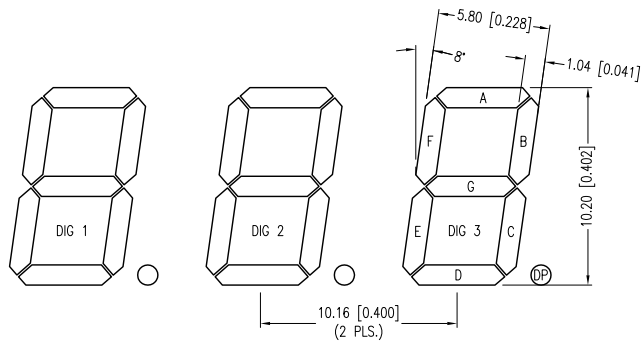
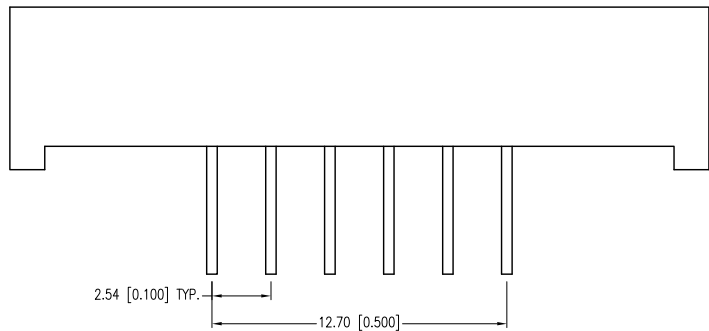
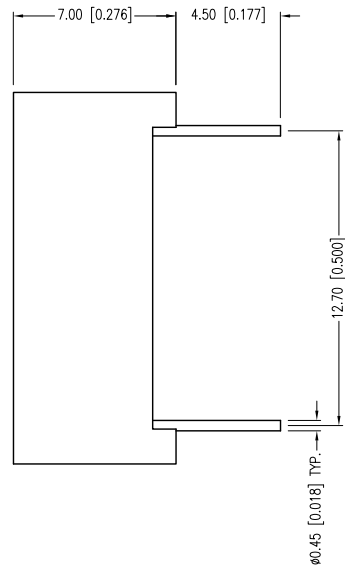
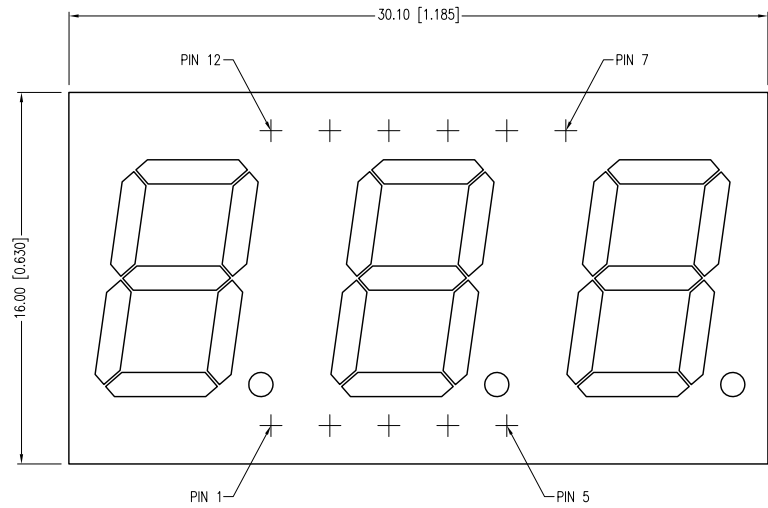

ELECTRO-OPTICAL CHARACTERISTICS Ta=25°C If=10mA

PARAMETER	MIN	TYP	MAX	UNITS	TEST COND
PEAK WAVELENGTH		636		nm	
FORWARD VOLTAGE		2.0	2.5	Vf	
REVERSE VOLTAGE	5.0			Vr	Ir=100µA
AXIAL INTENSITY		13,000		µcd	If=10mA
EMITTED COLOR:	RED				
FACE COLOR:	GRAY				
LENS FINISH:	MILKY WHITE DIFFUSED				

LIMITS OF SAFE OPERATION AT 25°C PER CHIP

PARAMETER	MAX	UNITS
PEAK FORWARD CURRENT*	150	mA
STEADY CURRENT	30	mA
POWER DISSIPATION	105	mW
DERATE FROM 25°C	-1.2	mW/°C
OPERATING TEMP.	-40 TO +85	°C
STORAGE TEMP.	-40 TO +85	°C
SOLDERING TEMP.	+260	°C
2.0mm FROM BODY	3	SEC.

* t<10µs

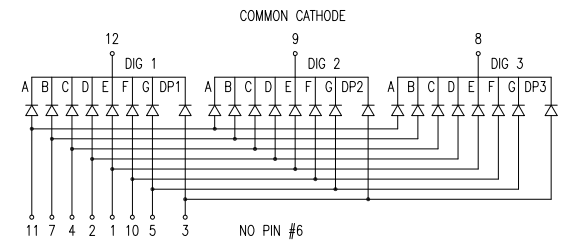

*UNLESS OTHERWISE SPECIFIED TOLERANCES PER DECIMAL PRECISION ARE: X=±1 (±0.039), X.X=±0.5 (±0.020), X.XX=±0.25 (±0.010), X.XXX=±0.127 (±0.005). LEAD SIZE=±0.05 (±0.002), LEAD LENGTH=±0.75 (±0.030). MIN= +DECIMAL PRECISION MAX.= -DECIMAL PRECISION UNCONTROLLED DOCUMENT

LUMEX
 Creating LED and LCD Solutions Together™

290 E. HELEN ROAD
 PALATINE, IL 60067-6976
 PHONE: +1.847.359.2790
 FAX: +1.847.359.6538
 WEB: WWW.LUMEX.COM
 MEMBER OF ITW PHOTONICS GROUP

QUASARBRITE 0.40" 3 DIGIT 7 SGM T DISPLAY, 636nm RED, COMMON CATHODE, MULTIPLEXED.

THE SPECIFICATIONS MAY CHANGE AT ANY TIME WITHOUT NOTICE DUE TO NEW MATERIALS OR PRODUCT IMPROVEMENT.

CONFIDENTIAL INFORMATION
 THE INFORMATION CONTAINED IN THIS DOCUMENT IS THE PROPERTY OF LUMEX INC. EXCEPT AS SPECIFICALLY AUTHORIZED IN WRITING BY LUMEX INC., THE HOLDER OF THIS DOCUMENT SHALL KEEP ALL INFORMATION CONTAINED HEREIN CONFIDENTIAL AND SHALL PROTECT SAME IN WHOLE OR IN PART FROM DISCLOSURE AND DISSEMINATION TO ALL THIRD PARTIES.

DATE:	07.31.12	DRAWN BY:	AB
PAGE:	1 OF 1	CHKD BY:	SS
SCALE:	NTS	APRVD BY:	SS
UNIT:	mm [INCH]		Ⓟ